

සියලු ම හිමිකම් ඇවිරිණි / முழுப் பதிப்புரிமையுடையது / All Rights Reserved

ශ්‍රී ලංකා විභාග දෙපාර්තමේන්තුව ශ්‍රී ලංකා විභාග දෙපාර්තමේන්තුව ශ්‍රී ලංකා විභාග දෙපාර්තමේන්තුව ශ්‍රී ලංකා විභාග දෙපාර්තමේන්තුව ශ්‍රී ලංකා විභාග දෙපාර්තමේන්තුව
 இலங்கைப் பரீட்சைத் திணைக்களம் இலங்கைப் பரීட்சைத் திணைக்களம் இலங்கைப் பரීட்சைத் திணைக்களம் இலங்கைப் பரීட்சைத் திணைக்களம் இலங்கைப் பரීட்சைத் திணைக்களம்
 Department of Examinations, Sri Lanka Department of Examinations, Sri Lanka Department of Examinations, Sri Lanka Department of Examinations, Sri Lanka Department of Examinations, Sri Lanka
 ශ්‍රී ලංකා විභාග දෙපාර්තමේන්තුව ශ්‍රී ලංකා විභාග දෙපාර්තමේන්තුව ශ්‍රී ලංකා විභාග දෙපාර්තමේන්තුව ශ්‍රී ලංකා විභාග දෙපාර්තමේන්තුව ශ්‍රී ලංකා විභාග දෙපාර්තමේන්තුව
 இலங்கைப் பரීட்சைத் திணைக்களம் இலங்கைப் பரීட்சைத் திணைக்களம் இலங்கைப் பரීட்சைத் திணைக்களம் இலங்கைப் பரීட்சைத் திணைக்களம் இலங்கைப் பரීட்சைத் திணைக்களம்

අධ්‍යයන පොදු සහතික පත්‍ර (උසස් පෙළ) විභාග, 2017 අගෝස්තු
 கல்விப் பொதுத் தராதரப் பத்திர (உயர் தர) பரீட்சை, 2017 அகஸ்ட்
 General Certificate of Education (Adv. Level) Examination, August 2017

භෞතික විද්‍යාව I
 பௌதிகவியல் I
 Physics I

01 E I

පැය දෙකයි
 இரண்டு மணித்தியாலம்
 Two hours

Instructions:

- * This question paper consists of 50 questions in 10 pages.
- * Answer all the questions.
- * Write your **Index Number** in the space provided in the answer sheet.
- * Read the instructions given on the back of the answer sheet carefully.
- * In each of the questions 1 to 50, pick one of the alternatives from (1), (2), (3), (4), (5) which is correct or most appropriate and mark your response on the answer sheet with a cross (x) in accordance with the instructions given on the back of the answer sheet.

Use of calculators is not allowed.

(Acceleration due to gravity, $g = 10 \text{ N kg}^{-1}$)

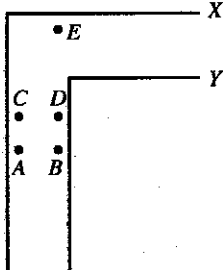
1. Unit of current density is
 (1) A m^2 (2) A m^{-2} (3) A m^{-3} (4) A m^{-1} (5) A m
2. a , b , c and d are physical quantities having different dimensions, and k is a dimensionless constant. Consider the following relationships.
 (A) $ka^3 = b$ (B) $d = ac$ (C) $a = kb$
 Of the above relationships
 (1) only B is dimensionally valid.
 (2) only C is dimensionally valid.
 (3) only A and B are dimensionally valid.
 (4) only A and C are dimensionally valid.
 (5) all A, B and C are dimensionally valid.
3. A uniform thin wire is bent into a wire-frame with its two ends X and Y kept opened as shown in the figure. The centre of gravity of the wire-frame is most likely to be at the point,
 (1) A (2) B (3) C (4) D (5) E

4. A tube with one end closed resonates at its fundamental frequency with a tuning fork of frequency f . When the closed end is opened, the same length of the tube will resonate at its fundamental frequency with a tuning fork of frequency approximately equal to
 (1) $\frac{f}{4}$ (2) $\frac{f}{2}$ (3) f (4) $2f$ (5) $4f$
5. A potentiometer is not used for
 (1) comparing resistances.
 (2) comparing e.m.f.s.
 (3) measuring the internal resistance of a cell.
 (4) measuring very small e.m.f.s.
 (5) measuring varying voltages.
6. Two rods A and B are connected end to end. Sound wave travelling in rod A has a speed v . If it enters the rod B whose Young's modulus is four times that of A but having the same density as A, the speed of the sound wave in rod B will be
 (1) $\frac{v}{4}$ (2) $\frac{v}{2}$ (3) v (4) $2v$ (5) $4v$

[See page two

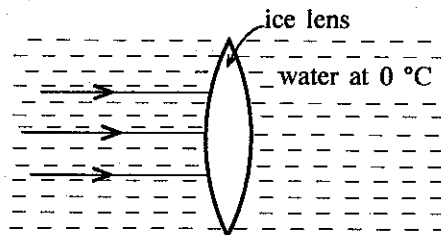
7. A thin transparent convex lens made of ice is immersed in water at 0°C , and rays of parallel light are made to incident on the lens as shown in the figure. Refractive indices of ice and water relative to air are 1.31 and 1.33 respectively. Consider the following statements.



- (A) Parallel light rays get converged to a point on the right side far away from the lens.
- (B) Ice lens behaves as a diverging lens under this situation.
- (C) Real images cannot be observed under this situation.

Of the above statements,

- (1) only A is true.
- (2) only B is true.
- (3) only C is true.
- (4) only A and C are true.
- (5) only B and C are true.

8. Current drawn from the battery in the circuit shown is

- (1) $\frac{V}{6R}$
- (2) $\frac{20V}{27R}$
- (3) $\frac{V}{21R}$
- (4) $\frac{27V}{182R}$
- (5) $\frac{137V}{882R}$

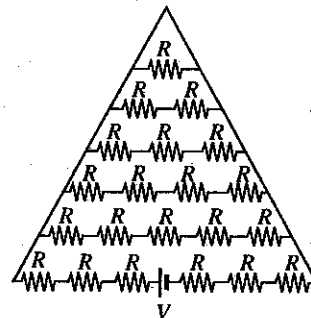

9. In a compound microscope under normal adjustment,

- (1) the object distance is less than the focal length of the objective.
- (2) the image formed by the objective is virtual.
- (3) the image formed by the objective is located within the focal length of the eyepiece.
- (4) the final image is real.
- (5) overall angular magnification can be increased by using an objective having a larger focal length.

10. A body executes simple harmonic motion along the x -axis around the point O . The variation of the acceleration (a) of the body with the displacement (x) from O is correctly represented in

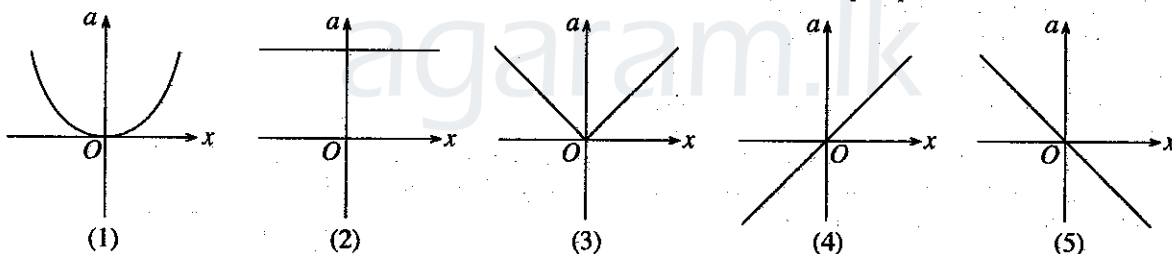

11. Which of the following statements is **not** true regarding progressive transverse waves in a stretched string?

- (1) Direction of the motion of particles in the string is normal to the direction of propagation of the wave.
- (2) Speed of the wave is inversely proportional to the square root of the mass per unit length of the string when the tension of the string is constant.
- (3) Energy carried by the wave depends on the amplitude of the wave.
- (4) Waves formed on the string cannot be reflected.
- (5) Two adjacent particles of the string do not move with the same speed at a given instant.

12. A solid sphere at $\theta^{\circ}\text{C}$ with volume expansivity γ_s is completely immersed and floating in a liquid at $\theta^{\circ}\text{C}$ as shown in the figure. Volume expansivity of the liquid is $\gamma_f (> \gamma_s)$. The **entire** sphere with the liquid is cooled down to a certain temperature.

Consider the following statements.

- (A) A part of the sphere will be above the surface of the liquid after cooling.
- (B) The magnitude of the upthrust acting on the sphere will not change.
- (C) The density of the sphere will be greater than the liquid after cooling.

Of the above statements,

- (1) only A is true.
- (2) only B is true.
- (3) only A and B are true.
- (4) only B and C are true.
- (5) all A, B and C are true.

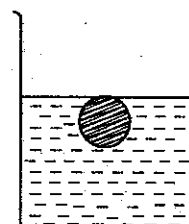

[See page three

13. A solid block of metal of volume 1 m^3 and density $8 \times 10^3 \text{ kg m}^{-3}$ rests at the bottom of a lake. What is the volume of a helium filled balloon connected as shown in the figure to make the block just float at the bottom of the lake? Neglect the mass of the balloon with helium. (Density of water = $1 \times 10^3 \text{ kg m}^{-3}$)
- (1) 7 m^3 (2) 8 m^3 (3) 70 m^3
 (4) 80 m^3 (5) 700 m^3

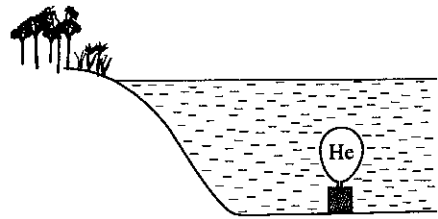

14. One of the surfaces of a glass prism of refractive index 1.5, is silvered as shown in the figure. A ray of light falling on the face AB with an angle of incidence θ gets reflected from the silvered surface and returns along the same path. Which one of the following values is closest to θ ?
- (1) 37° (2) 41° (3) 49°
 (4) 51° (5) 56°

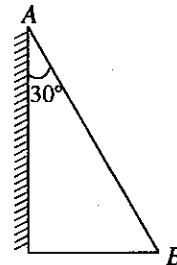

15. Figure shows a distribution of static electric charges enclosed by a Gaussian surface S. X is an unknown charge. If the net outward electric flux through the surface S is $\frac{-q}{\epsilon_0}$, then charge X is
- (1) $-3q$ (2) $-2q$ (3) $-q$
 (4) $+q$ (5) $+2q$

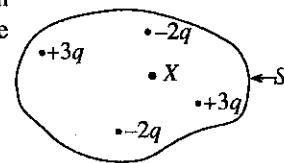

16. Three identical uniform metal discs are perforated to form twelve holes in each disc with three different radii as shown in the figures (A), (B) and (C). The three discs A, B and C when arranged so that their moments of inertia, about an axis normal to the plane of the disc and passing through the centre, are in the ascending order, is
- (1) B, C, A (2) A, B, C (3) C, B, A
 (4) A, C, B (5) B, A, C

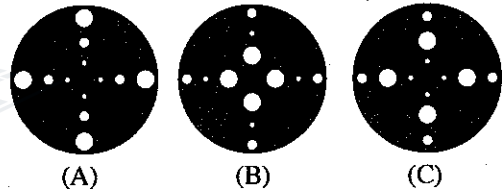

17. A person with surface body temperature 30°C is in an environment of temperature 20°C . The net rate of loss of heat due to radiation from the body is proportional to (Assume that the black body radiation-conditions can be applied.)
- (1) $303^4 - 293^4$ (2) 293^4 (3) 10^4 (4) $303^4 + 293^4$ (5) $30^4 - 20^4$

18. When the transistor shown in the circuit is biased in the active mode, the collector current will be
- (1) 0.60 mA (2) 0.80 mA (3) 1.25 mA
 (4) 1.40 mA (5) 2.50 mA

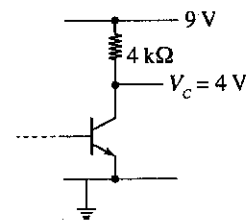

19. When the switch S is closed in the circuit shown,
- (1) only A will glow.
 (2) only B and C will glow.
 (3) only B and D will glow.
 (4) only B, C and D will glow.
 (5) all A, B, C and D will glow.

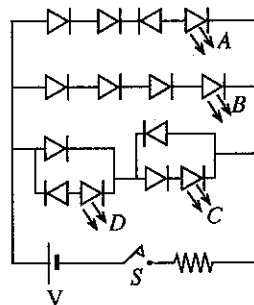

[See page four

Agaram.LK - Keep your dreams alive!

Agaram.LK - Keep your dreams alive!

20. Two digital voltage waveforms *A* and *B* shown are connected to the two inputs of the gate shown.

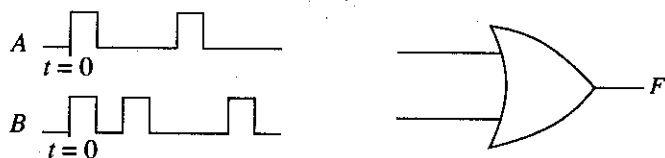

The correct output voltage waveform at *F* is

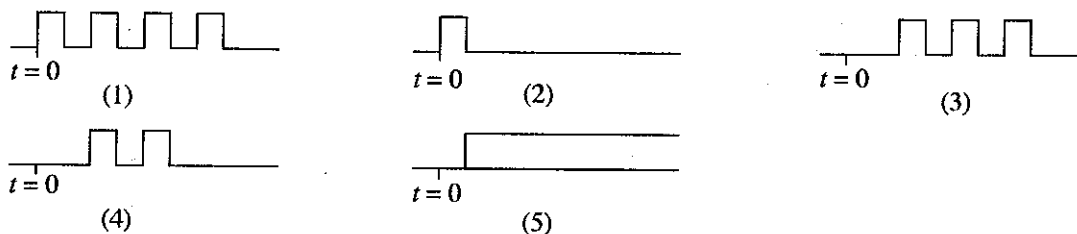

21. A beam of monochromatic light is incident on a metal surface which is capable of producing photoelectrons. If the frequency of the light is above the cut-off frequency of the metal, the number of photoelectrons ejected from the metal surface is proportional to the

- (1) reciprocal of the kinetic energy of a photoelectron.
- (2) work function of the metal.
- (3) frequency of the incident light.
- (4) number of photons that hits the metal surface.
- (5) energy of a single photon.

22. Positions of three motor cars ①, ② and ③ travelling along three parallel straight lanes of a road at time $t = 0$, and $t = t_0$ are shown in figure (a), and their corresponding velocity (v)–time (t) graphs are shown in figure (b).

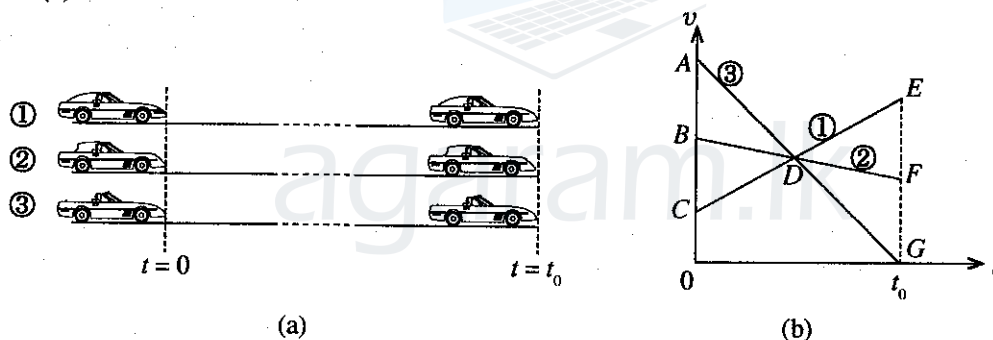

The situation shown in figure (a) could have happened only if the areas in the graphs satisfy the conditions

- (1) $ABD = DEF$ and $ABD = DEG$
- (2) $BCD = DEF$ and $ABD = DFG$
- (3) $CDB = DEG$ and $ABD = DEF$
- (4) $BCD = ABD$ and $DEF = DFG$
- (5) $ACD = DFG$ and $BCD = DFG$

23. A monkey climbed a certain vertical height along a vertical rope with uniform speed in 30 seconds. (See figure.) Later the same monkey climbed the same vertical height along a spiral-path of 75 m path length with another uniform speed. If the monkey applied the same power throughout its motion in both cases, the speed with which the monkey has climbed the spiral path is

- (1) 0.33 m s^{-1}
- (2) 2.5 m s^{-1}
- (3) 5 m s^{-1}
- (4) 7.5 m s^{-1}
- (5) 10 m s^{-1}

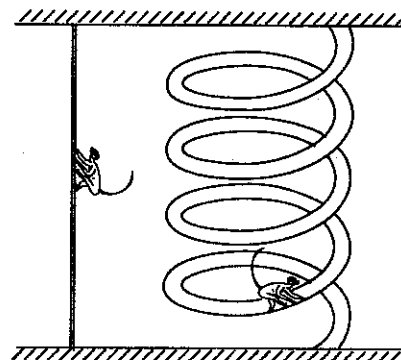

[See page five

24. In the figure shown F_1 , F_2 and F_3 represent fixed vectors of three forces acting at the point O in the x - y plane. F_4 is a vector representing a rotating force about the point O in the same x - y plane. Which of the following best represents the **direction** of the resultant vector, when the vector F_4 is at angles $\theta=0^\circ$, 90° , and 180° ?

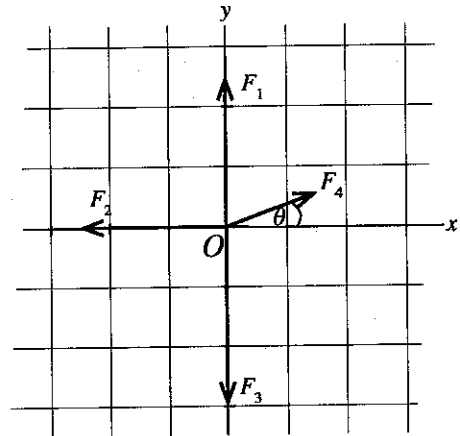

	0°	90°	180°
(1)	→	←	→
(2)	←	←	←
(3)	←	→	→
(4)	→	←	←
(5)	←	→	←

25. A pipe line laid horizontally carries a liquid of density d at a constant speed v from a pressurized large over-head tank. Pipe line passes through a shallow region of muddy water as shown in the figure. Pressure above the liquid surface in the over-head tank is P and the atmospheric pressure is P_0 . Suppose a small crack has been developed on the pipe at X . The condition for muddy water to seep into the pipe is (Assume that the liquid level in the tank is maintained at a constant height h from the ground, and that the seeping of muddy water does not change the speed v .)

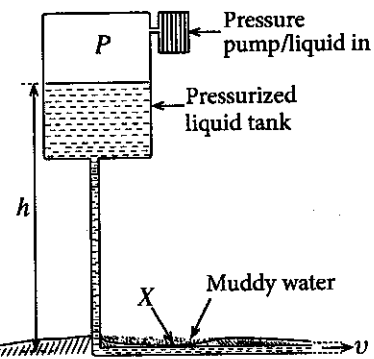

- (1) $P + P_0 < hdg + \frac{1}{2} dv^2$ (2) $hdg - \frac{1}{2} dv^2 < P_0$
 (3) $P + hdg - \frac{1}{2} dv^2 < P_0$ (4) $P + \frac{1}{2} dv^2 + hdg < P_0$
 (5) $P + hdg < P_0$

26. In the circuit shown, each cell has e.m.f. E and internal resistance r . Current I is given by

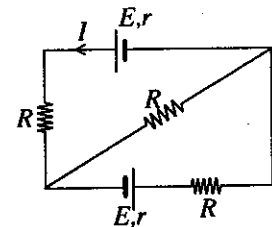

- (1) $\frac{2E}{R+r}$ (2) $\frac{2E}{4R+r}$ (3) $\frac{E}{2(R+r)}$
 (4) $\frac{E}{R+r}$ (5) 0

27. The part of a smooth horizontal loop $CDEFGH$ in the figure consists of a non-conducting part $DEFG$ and two conducting rails CD and GH . A thin straight conducting wire XY is placed on the rails and a soap film of surface tension T is formed in the region $DEFGD$. A magnetic field of flux density B is applied in the direction shown. The magnitude and the direction of the current needed to setup through DG in order to hold the soap film stationary is

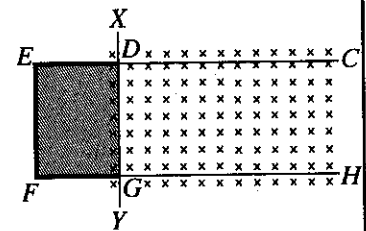

- (1) $\frac{T}{2B}$ in the direction of $D \rightarrow G$. (2) $\frac{2T}{B}$ in the direction of $G \rightarrow D$.
 (3) $\frac{2T}{B}$ in the direction of $D \rightarrow G$. (4) $\frac{4T}{B}$ in the direction of $G \rightarrow D$.
 (5) $\frac{4T}{B}$ in the direction of $D \rightarrow G$.

28. If the coefficient of viscosity of all fluids is reduced below the existing value without reaching the conditions for turbulence, which of the following is **not** true?

- (1) Liquid flow rates in narrow tubes will be higher.
 (2) Heart may have to do less work to pump blood.
 (3) Sucking cool drinks using a straw is easier.
 (4) Resistance due to air drag on moving motor cars will decrease.
 (5) Terminal speeds acquired by rain drops will become smaller.

[See page six

29. Four charges each of $+q$ are fixed at the vertices of a square $ABCD$ as shown in the figure. A movable particle with charge $-q$ is placed at the centre O of the square. If the two charges at A and B are vanished simultaneously, which of the following is **not true** regarding the movement of the particle with charge $-q$? (Neglect the gravitational effects and the air resistance on the particle.)

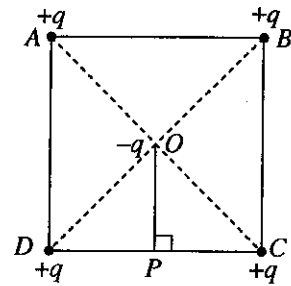

- (1) It will begin to accelerate in the direction OP .
- (2) Speed of the particle becomes maximum at P .
- (3) Once it arrives at P from O , it will move a further distance of magnitude OP along OP direction.
- (4) It will always have maximum acceleration at P .
- (5) It will again return to O .

30. As shown in the figure (b), an alternating voltage source v_i producing the voltage waveform shown in figure (a) is connected to the primary circuit of a transformer. The primary circuit is now connected to a dc potential of 5 kV as shown in figure (c). Assume that the primary coil is well insulated electrically from the secondary coil.

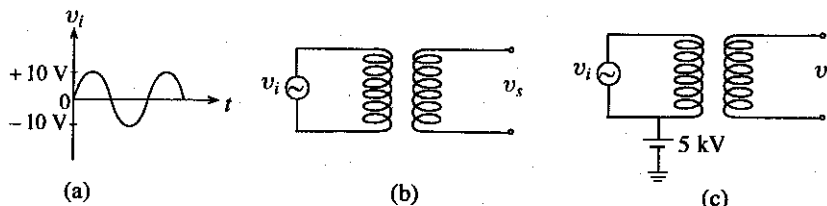

Which of the following figures correctly represents the voltage waveform v_s in figure (c) of the secondary circuit?

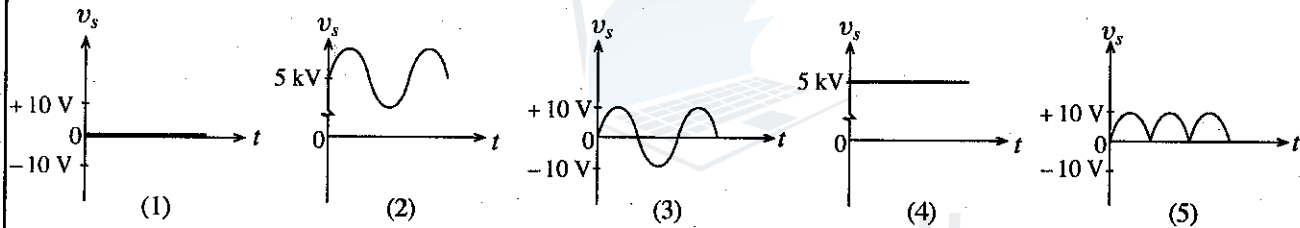

31. Part of a huge man-made garbage dump on a large marshy land suddenly collapsed and sank **ejecting nearby houses up** which had been built on the marshy land.

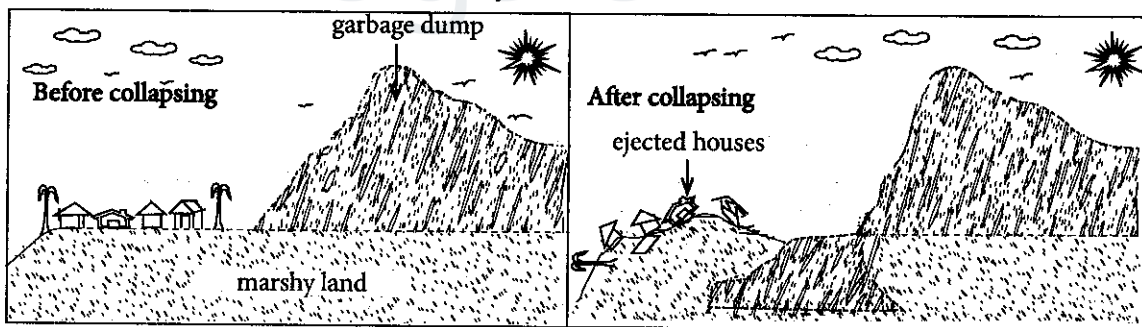

Which of the following physics principles that you have learnt is most suitable to understand the ejecting the houses up?

- (1) Principle of flotation
- (2) Principle of conservation of momentum
- (3) Archimedes' principle
- (4) Pascal's principle
- (5) Principle of moments

32. A certain mass of an ideal gas is taken from A through a cyclic process $ABCD A$ as shown in the P - V diagram. Which of the following is **not true**?

- (1) Work done by the gas through the section of the path ABC is equal to the area $ABCLKA$.
- (2) Net heat absorbed by the gas after completing the cycle is zero.
- (3) Net work done by the gas after completing the cycle is equal to the area $ABCD A$.
- (4) Net change in internal energy of the gas after completing the cycle is zero.
- (5) Net change in temperature of the gas after completing the cycle is zero.

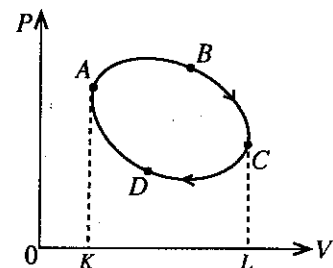

[See page seven

33. A flute maker produces a flute in a location where the speed of sound in air is 330 ms^{-1} so that when the note A is played, it occurs exactly at 440 Hz. A flutist plays note A with this flute in a different location where the speed of sound in air is 333 ms^{-1} . If a tuning fork of 440 Hz is sounded simultaneously with the note A of this flute, at the new location, how many beats per second will the flutist hear?
 (1) 2 (2) 4 (3) 8 (4) 10 (5) 12

34. Two conducting loops A and B, made of a material that is not attracted to magnets are placed on a frictionless insulated rail as shown in the figure. The loops are free to move along the rail, and the planes of the loops are perpendicular to the rail. The two loops and the bar magnet kept between the loops are initially at rest. The bar magnet is then suddenly moved to the right as shown in the figure. As a result,
 (1) both loops A and B move towards right.
 (2) both loops A and B move towards left.
 (3) loops A and B move towards each other.
 (4) loops A and B move away from each other.
 (5) both loops A and B will remain at rest.

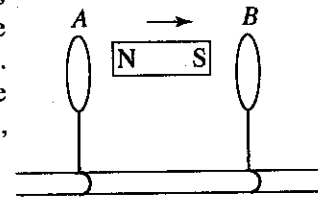

35. Figure shows an insulated network of heat reservoirs X, B, C, D and E of which C, D and E are identical. The reservoir X operating at 100°C supplies heat and maintains the four other reservoirs B, C, D and E at the temperatures shown. Heat is supplied by connecting the reservoirs with insulated heat conducting rods of same material and having identical areas of cross-section. Lengths of the rods are not drawn to the scale. If the length of the conducting rod between X and B is L , the length of the conducting rod between B and D will be

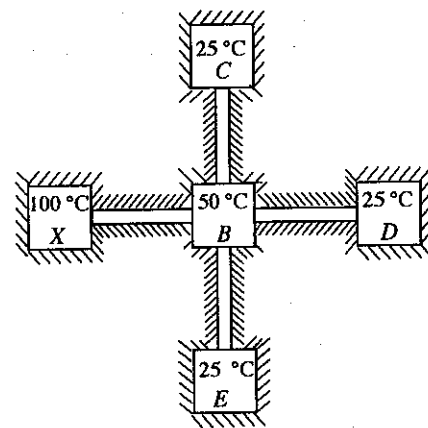

- (1) $2L$ (2) $\frac{3L}{2}$ (3) L
 (4) $\frac{2L}{3}$ (5) $\frac{L}{2}$
36. In an experiment to determine the specific latent heat of fusion (L) of ice using method of mixtures, a student obtained a value for L which is less than the standard value. Reasons for the lower value for L have been explained by the student with following statements.
 (A) It may have been due to the dew being formed on the outer surface of the calorimeter while doing the experiment.
 (B) Water on the pieces of ice may have not been properly wiped out before adding to the calorimeter.
 (C) Temperature of the ice used may have been lower than 0°C .

Of the above statements,

- (1) only A can be accepted. (2) only B can be accepted.
 (3) only A and B can be accepted. (4) only B and C can be accepted.
 (5) all A, B and C can be accepted.
37. A person wearing sweated clothes of temperature 35°C has to enter to one of the three large closed rooms X, Y and Z which are maintained at 40°C , 35°C and 20°C , respectively. Assume that all the rooms are saturated with water vapour. Consider the following statements.
 (A) If the person enters the room X, initially some of the sweat will begin to evaporate.
 (B) If the person enters the room Y, sweat will not evaporate.
 (C) If the person enters the room Z, initially some of the sweat will begin to evaporate.

Of the above statements,

- (1) only A is true. (2) only B is true.
 (3) only A and B are true. (4) only B and C are true.
 (5) all A, B and C are true.

38. The height of a vertical uniform rod, when one end is firmly fixed to a horizontal surface in air as shown in figure (a) is L . Then the other end of the rod is kept in a vacuum chamber hung from the roof as shown in figure (b). Assume that the chamber does not exert any force at contact points with the rod. Y is the Young's modulus of the material of the rod and P_0 is the atmospheric pressure. If L_0 is the height of the rod in figure (b), then the ratio $\frac{L}{L_0}$ is given by

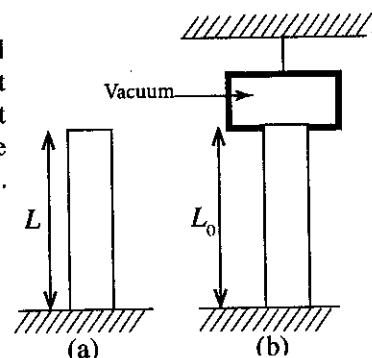

- (1) $1 - \frac{P_0}{Y}$ (2) $\left(1 - \frac{P_0}{Y}\right)^{-1}$ (3) $\frac{P_0}{Y} - 1$
 (4) $\frac{P_0}{Y} + 1$ (5) $1 - \frac{Y}{P_0}$

[See page eight

39. The figures (A), (B) and (C) show a moving sound source S producing different frequencies f_1 , f_2 and f_3 at three different situations. O is an observer carrying a sound frequency detector. Speed and the direction of motion of the source and the observer in each situation are shown in the figures. If the detector detects the same value for the frequency in all three situations,

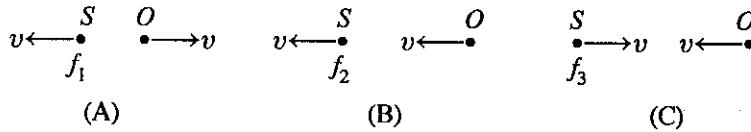

the frequencies produced by the sound source when arranged in the ascending order is

- (1) f_1, f_2, f_3 (2) f_3, f_2, f_1 (3) f_1, f_3, f_2 (4) f_2, f_3, f_1 (5) f_2, f_1, f_3

40. When the switch S in the circuit is closed at time $t = 0$, the voltage V of the power supply varies with time (t) according to the equation $V = Kt^2$, where the magnitude of K is 2. The variation of the power dissipation (P) in the 4Ω resistor with time (t) is best represented by

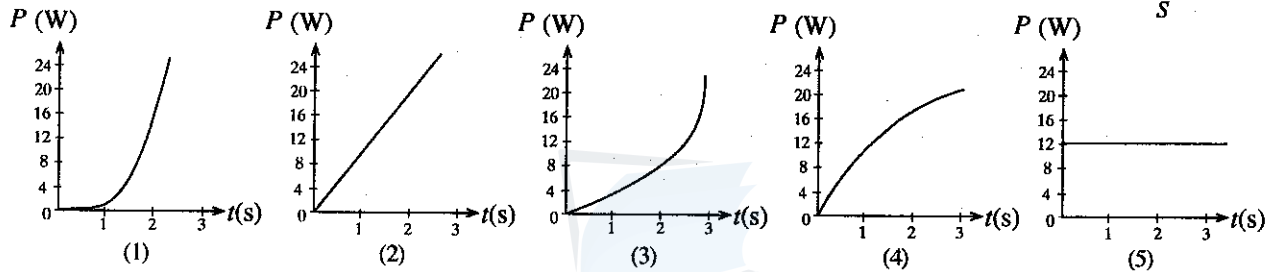
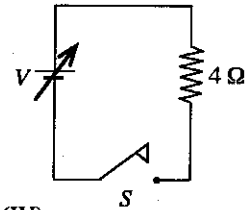

41. In the circuit shown V_1 is a variable voltage provided by a battery. Variation of the potential V_A at point A with respect to the earth, with V_1 is best represented by (Neglect the internal resistances of both power supplies.)

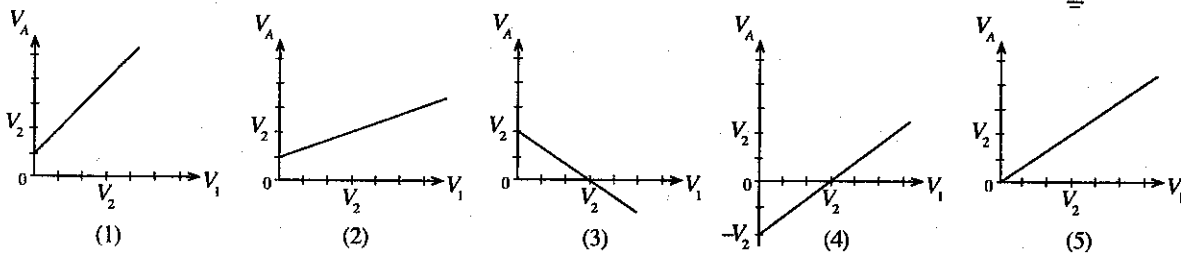
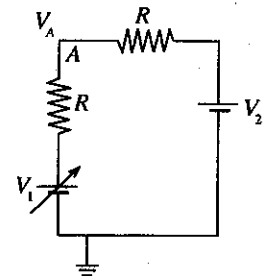

42. A volume V of a mixture of ideal gases contains n_A moles of gas A and $n_B (< n_A)$ moles of gas B at a constant temperature. The variation of the partial pressures P_A and P_B of the gases A and B respectively, and the overall pressure P_M of the mixture with $\frac{1}{V}$ at the above constant temperature is best represented in

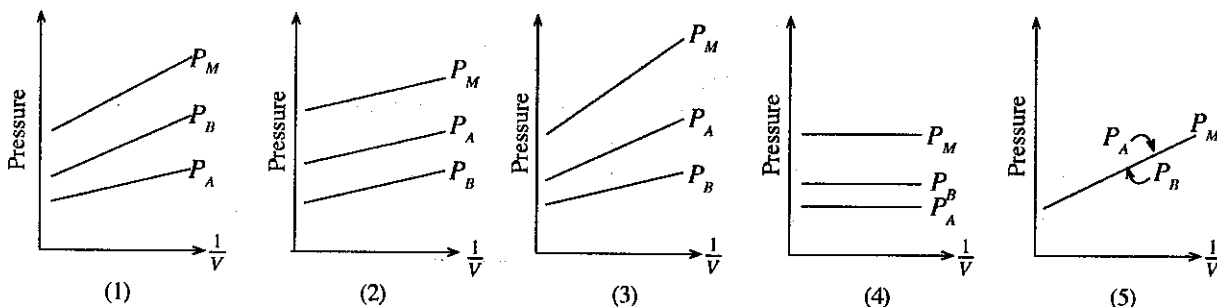

43. A river flows steadily at a constant velocity v . A rectangular block of wood having density less than that of water is first held above the surface of water so that it is stationary with respect to the riverbank, and then slowly lowered to the water until the floating condition is achieved and then released it, as shown in figure. Assume that the initial speed of the wooden block in the direction of v is zero. During the subsequent motion of the block, which of the following is true for magnitudes of the impulsive force acting on the block, the viscous force acting on the block by water, and the momentum of the block? (Neglect effect due to air drag.)

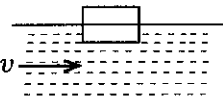

	Impulsive force	Viscous force	Momentum
(1)	Decreases from a higher value to zero	Increases and becomes constant	Decreases from a higher value to zero
(2)	Increases and becomes constant	Decreases from a higher value to zero	Increases and becomes constant
(3)	Decreases from a higher value to zero	Increases and becomes constant	Increases and becomes constant
(4)	Increases and becomes constant	Increases and becomes constant	Decreases from a higher value to zero
(5)	Decreases from a higher value to zero	Decreases from a higher value to zero	Increases and becomes constant

44. A uniform solid wheel rolls along a flat surface at a uniform velocity v without slipping as shown in the figure. P is a point on the circumference of the wheel. Location of the point P at $t = 0$ is also shown in the figure.

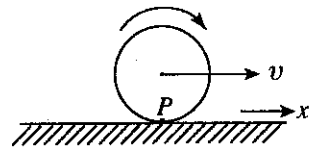

Variation of the horizontal component of the velocity (v_x) of the point P with respect to the surface with time (t) is best represented by

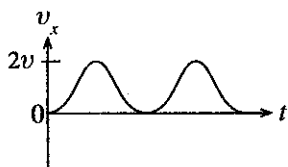

(1)

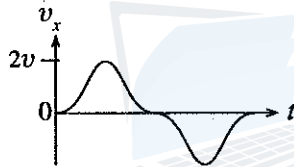

(2)

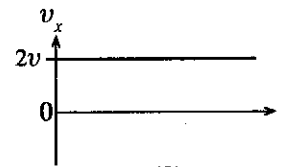

(3)

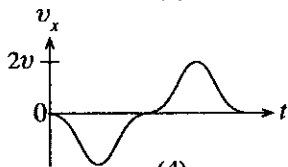

(4)

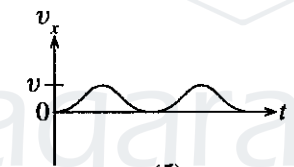

(5)

45. Figures (A), (B) and (C) show distributions of a positive charge Q in three situations. In figure (A), charge Q exists as a point charge placed at a distance R from point P . In figure (B), the charge Q is uniformly distributed in the form of a thin circular arc of radius R with its centre located at point P . In figure (C), charge Q is uniformly distributed in the form of a thin ring of radius R , with its centre at point P . If the potentials, and the magnitudes of the intensity of the electric fields at points P in the situations (A), (B) and (C) are V_A, V_B, V_C , and E_A, E_B, E_C respectively, which of the answers given is true?

	Potentials at points P	Magnitudes of the intensity of the electric fields at points P
(1)	$V_A > V_B > V_C$	$E_A > E_B > E_C$
(2)	$V_A > V_B > V_C$	$E_C > E_B > E_A$
(3)	$V_A = V_B = V_C$	$E_A = E_B = E_C$
(4)	$V_A = V_B = V_C$	$E_A = E_C > E_B$
(5)	$V_A = V_B = V_C$	$E_A > E_B > E_C$

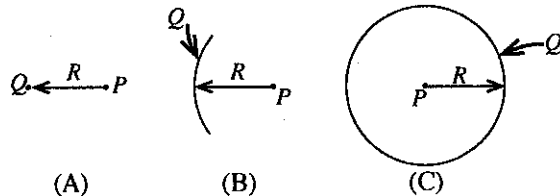

46. A rectangular block rests on an inclined plane as shown in figure (a). The direction of the resultant force F exerted on the inclined plane by the block is best represented by

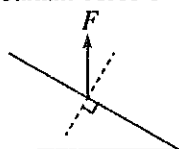
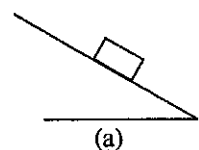

(1)



(2)



(3)

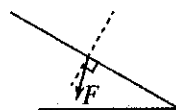

(4)

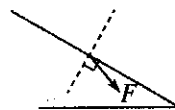

(5)

[See page ten

47. Variation of the output potential (V) with time (t) of an alternating voltage generator connected to one plate of an uncharged parallel plate capacitor is shown in the figure. The other plate X of the capacitor is kept unconnected. The variation of the potential (V_x) of the plate X with time (t) is best represented by

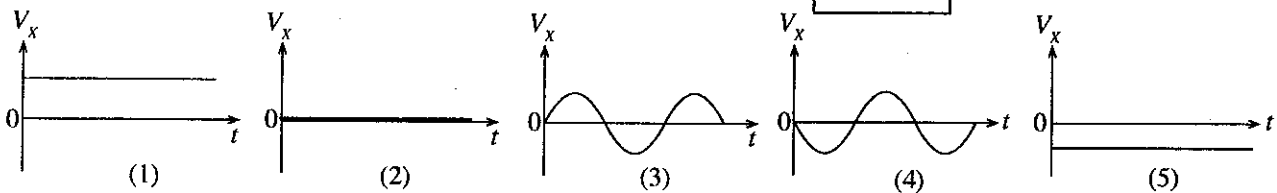
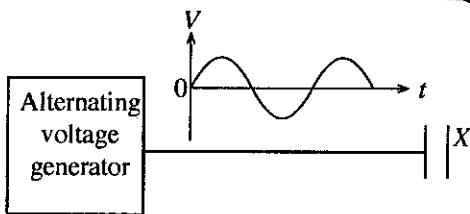

48. AB and CD represent two parallel straight long conducting wires fixed to a horizontal plane and carrying current I in each of them. L is a conducting square loop placed on the same horizontal plane, as shown in the figure. XY is the centre line between AB and CD . Consider the following statements made when the loop L is moving towards CD on the same plane at a constant speed.

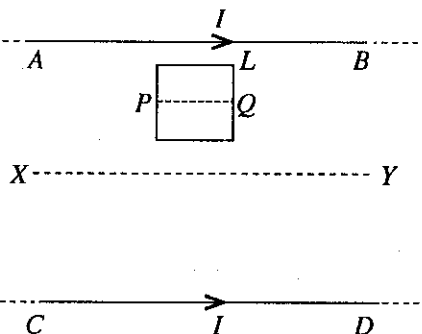

- (A) The induced current in the loop gradually increases as it moves toward XY .
- (B) The direction of the induced current in the loop is always clock-wise.
- (C) The induced current in the loop is zero at the instant when the centre line PQ of the loop passes through the line XY .

Of the above statements,

- (1) only A is true.
- (2) only B is true.
- (3) only A and B are true.
- (4) only B and C are true.
- (5) all A, B and C are true.

49. A metal disc rotates in the clock-wise direction between north and south poles of a magnet as shown in the figure. The magnet produces a magnetic flux confined to a small region shown with dotted lines. Magnetic field produced is perpendicular to the plane of the disc. Which of the following figures shows the correct direction of the current in the eddy-current loops which are produced in this situation?

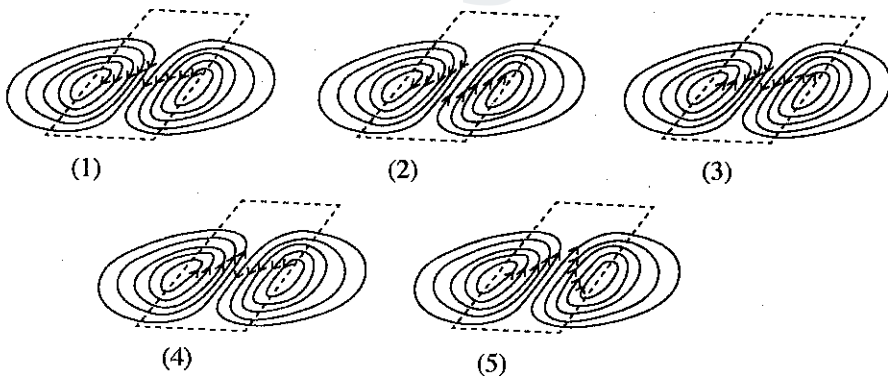
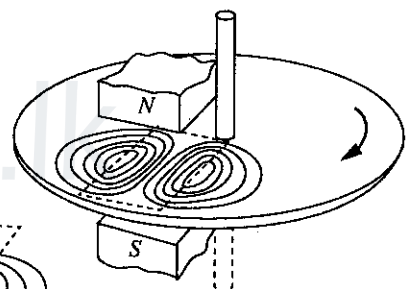

50. A small sphere is released from rest from point A in a firmly fixed frictionless track, which is a quarter of a circular path of centre O and radius r as shown in the figure. The sphere leaves the track horizontally at point B and falls under gravity until it hits the ground at a certain point C (C not shown). If the times taken and the distances travelled by the sphere from A to B and B to C are t_{AB} , t_{BC} and S_{AB} , S_{BC} respectively, which of the following is true?

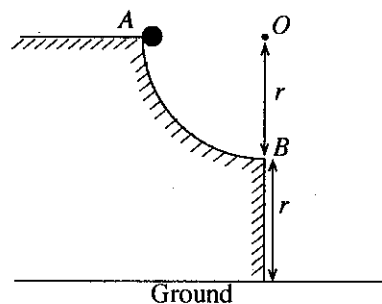

- (1) $t_{AB} > t_{BC}$ and $S_{AB} < S_{BC}$
- (2) $t_{AB} > t_{BC}$ and $S_{AB} > S_{BC}$
- (3) $t_{AB} = t_{BC}$ and $S_{AB} < S_{BC}$
- (4) $t_{AB} < t_{BC}$ and $S_{AB} = S_{BC}$
- (5) $t_{AB} = t_{BC}$ and $S_{AB} = S_{BC}$

ශ්‍රී ලංකා විභාග දෙපාර්තමේන්තුව ශ්‍රී ලංකා විභාග දෙපාර්තමේන්තුව ශ්‍රී ලංකා විභාග දෙපාර්තමේන්තුව ශ්‍රී ලංකා විභාග දෙපාර්තමේන්තුව ශ්‍රී ලංකා විභාග දෙපාර්තමේන්තුව
 இலங்கைப் பரீட்சைத் திணைக்களம் இலங்கைப் பரීட்சைத் திணைக்களம் இலங்கைப் பரීட்சைத் திணைக்களம் இலங்கைப் பரීட்சைத் திணைக்களம் இலங்கைப் பரීட்சைத் திணைக்களம்
 Department of Examinations, Sri Lanka Department of Examinations, Sri Lanka Department of Examinations, Sri Lanka Department of Examinations, Sri Lanka Department of Examinations, Sri Lanka
 இலங்கைப் பரීட்சைத் திணைக்களம் இலங்கைப் பரීட்சைத் திணைக்களம் இலங்கைப் பரීட்சைத் திணைக்களம் இலங்கைப் பரීட்சைத் திணைக்களம் இலங்கைப் பரීட்சைத் திணைக்களம்
 Department of Examinations, Sri Lanka Department of Examinations, Sri Lanka Department of Examinations, Sri Lanka Department of Examinations, Sri Lanka Department of Examinations, Sri Lanka

අධ්‍යයන පොදු සහතික පත්‍ර (උසස් පෙළ) විභාග, 2017 අගෝස්තු
 கல்விப் பொதுத் தராதரப் பத்திர (உயர் தர)ப் பரீட்சை, 2017 ஆகஸ்ட்
 General Certificate of Education (Adv. Level) Examination, August 2017

භෞතික විද්‍යාව II
 பௌதிகவியல் II
 Physics II

01 E II

පැය තුනයි
 மூன்று மணித்தியாலம்
 Three hours

Index No. :

Important :

- * This question paper consists of 13 pages.
- * This question paper comprises of two parts, Part A and Part B. The time allotted for both parts is three hours.
- * Use of calculators is not allowed.

PART A – Structured Essay :
 (pages 2 - 7)

Answer all the questions on this paper itself.
 Write your answers in the space provided for each question. Note that the space provided is sufficient for your answers and that extensive answers are not expected.

PART B – Essay :
 (pages 8 - 13)

This part contains six questions, of which, four are to be answered. Use the papers supplied for this purpose.

- * At the end of the time allotted for this paper, tie the two parts together so that Part A is on top of Part B before handing them over to the Supervisor.
- * You are permitted to remove only Part B of the question paper from the Examination Hall.

For Examiners' Use Only

For the second paper		
Part	Question Nos.	Marks Awarded
A	1	
	2	
	3	
	4	
B	5	
	6	
	7	
	8	
	9 (A)	
	9 (B)	
	10 (A)	
	10 (B)	
Total		

Final Marks

In numbers	
In words	

Code Numbers

Marking Examiner 1	
Marking Examiner 2	
Marks checked by	
Supervised by	

Agaram.LK - Keep your dreams alive!

Agaram.LK - Keep your dreams alive!

Do not write in this column

PART A – Structured Essay

Answer *all four* questions on this paper itself.

(Acceleration due to gravity, $g = 10 \text{ N kg}^{-1}$)

1. You are asked to find the mass M of a piece of rock of irregular shape having a mass of the order of 60 g by performing the experiment which uses the principle of moments. You are provided with **only** the following items to carry out the experiment.

- A weight of mass $m (= 50 \text{ g})$
- A metre ruler
- A knife-edge and a suitable wooden block
- Pieces of thread



(a) As the first step of this experiment, you are asked to balance the metre ruler on the knife-edge. What is the purpose of this step?

(b) Draw a diagram of the arranged experimental setup, on the table shown below, for the balanced situation just before you take a reading. Mark the balanced lengths l_1 and l_2 correctly (Take the larger balanced length as l_1) measured from the balanced point, in the diagram. Label the items.

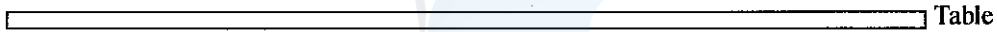

(c) Write down an expression for l_2 in terms of m , M and l_1 when the system is balanced.

(d) You are supposed to draw a graph in this experiment. What position of the metre ruler would you place on the knife-edge every time when you take a different set of readings for l_1 and l_2 ?

(e) Suppose you have plotted a graph as shown in figure (1) to find the mass M .

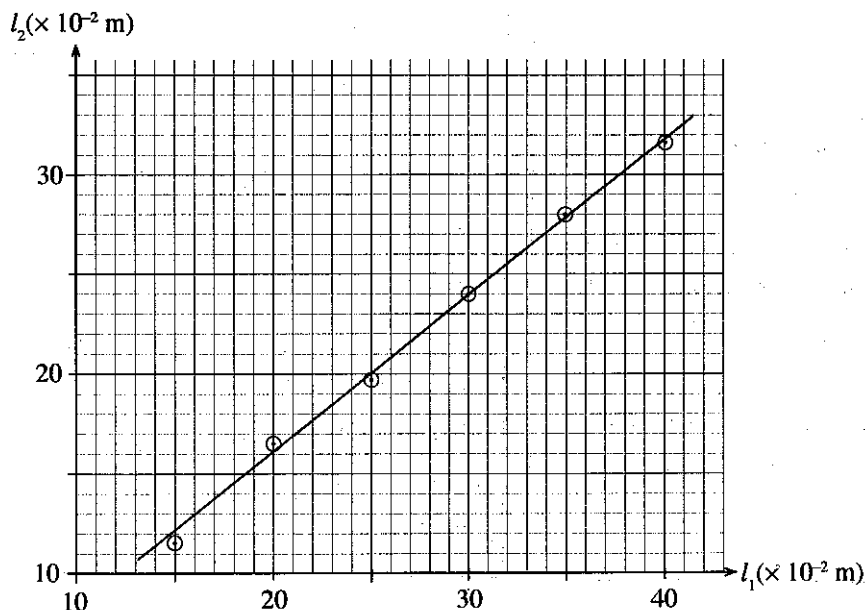

Figure (1)

[see page three

Do not write in this column

(i) In this experiment, you have been asked **not** to take readings for small values of l_1 and l_2 . What is the reason for this?

.....
.....

(ii) By selecting the two **most suitable** points on the graph, calculate the gradient of the graph given in figure (1). The **two** points selected should be clearly marked on the graph using arrows.

.....
.....
.....

(iii) Calculate the mass M of the piece of rock in kilograms.

.....
.....
.....

(f) You are also asked to find the mass m_0 of the metre ruler using only the other items provided above **except** the piece of rock. Draw a suitable diagram of an experimental setup that could be used for this situation in the space given below. The centre of gravity of the metre ruler should be clearly labelled as G .



2. The diagram shows an experimental setup that can be used to verify Newton's law of cooling, and to determine the specific heat capacity of a given liquid. It consists of a calorimeter with a lid and a stirrer made of copper, heated water, thermometer and a stand to hang the calorimeter setup. An experimental procedure similar to the method used in the standard experiment is performed by keeping the setup closer to an open window of the laboratory.

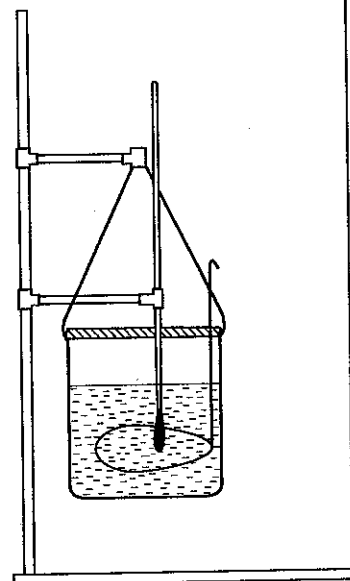

The advantage of doing this experiment near an open window where you get a slow uniform flow of wind is that you can verify the validity of the Newton's law of cooling for higher temperature differences.

(a) (i) What are the readings you would take in this experiment to verify the Newton's law of cooling?

(1)
.....
(2)
.....

[see page four

Do not write in this column

(ii) What is the experimental procedure to be performed which enables you to reliably assume that the reading of the thermometer is same as the temperature of the outer surface of the calorimeter?

.....

(iii) Draw rough sketches of the two graphs that you would plot to verify the Newton's law of cooling. Label the axes properly with appropriate units.

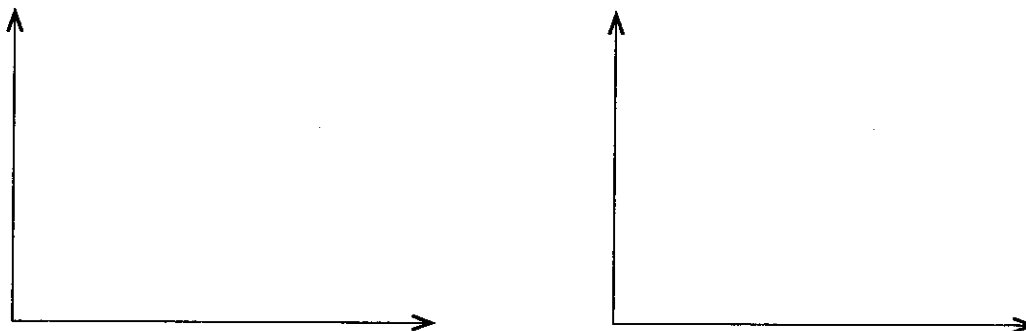

(b) In order to determine the specific heat capacity of a given liquid, the same procedure used in (a) above is repeated for the liquid after obtaining relevant readings for water.

(i) What is the reason for using the same calorimeter used in part (a) to perform this experiment?

.....

(ii) In addition to the using of same calorimeter, what is the reason for using the same volume of water and liquid in this experiment?

.....
.....

(iii) The mass and specific heat capacity of the calorimeter with the lid and the stirrer are m and s respectively. Mass and the specific heat capacity of the liquid are m_l and s_l respectively. The average rate of loss of heat and the average rate of drop of temperature of the calorimeter with the liquid for a given temperature range are H_m and θ_m respectively. In terms of these quantities, write down the relationship between H_m and θ_m .

.....
.....
.....

(iv) Let $m = 0.15 \text{ kg}$, $s = 400 \text{ J kg}^{-1} \text{ K}^{-1}$ and $m_l = 0.25 \text{ kg}$. For a certain temperature difference, the average rate of heat loss of the calorimeter with **water** was found to be 90 J s^{-1} . The average rate of drop of temperature of the calorimeter with the **liquid** for the same temperature difference was found to be 0.125 K s^{-1} . Determine the specific heat capacity s_l of the liquid.

.....
.....
.....
.....



Do not write in this column

3. You are asked to determine the mass per unit length of a given wire by taking only one measurement using a sonometer and a tuning fork. Figure shows a standard sonometer setup used in a school laboratory fixed with the **given wire**. The wire is stretched with a tension T between two bridges A and B . In this setup the bridge A is fixed and bridge B is allowed to move. The tension in the wire could be changed by varying the load mass M . A tuning fork with known frequency f is provided to you.

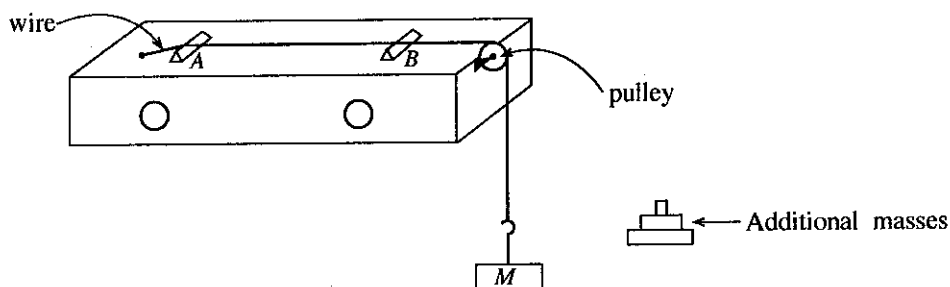

(a) What type of vibrations is produced in the surrounding air due to the vibration of a tuning fork in this experiment?

.....

(b) If m is the mass per unit length of the stretched wire of tension T , write down an expression for the speed v of transverse waves on the wire in terms of T and m .

.....

(c) In this experiment you are supposed to measure the resonant length (l) of the wire resonating with the tuning fork at the fundamental note. A student suggested that there can be three ways (A), (B) and (C) of keeping a vibrated tuning fork to obtain the resonance state, as shown in the figure.

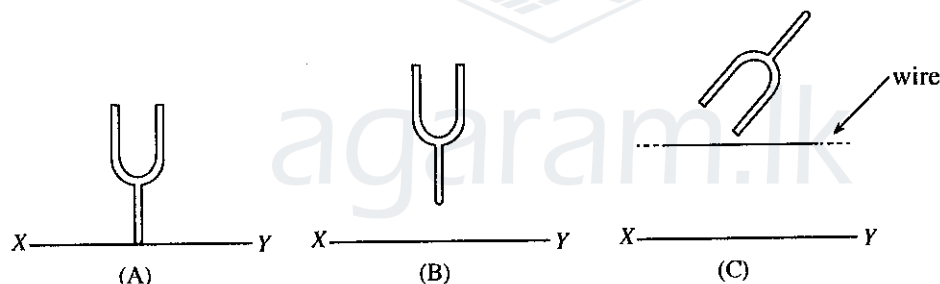

XY represents a part of the surface of the sonometer box.

(A) Tuning fork held normal to XY and touching XY .

(B) Tuning fork held normal to XY and without touching XY .

(C) Tuning fork held above the stretched wire.

In order to obtain maximum amplitude for resonance, out of the above three ways, which way would you select to keep the vibrated tuning fork? [(A) or (B) or (C)]. Give the reason for you selection.

.....

(d) Write down the other item that you normally use in this experiment to detect the **resonance state** experimentally.

.....

(e) Write down the main experimental steps you follow to detect the **optimum** resonance state.

.....

[see page six

Do not write in this column

(f) Obtain an expression for m in terms of f , l and T .

.....

(g) If the resonant length that you have obtained in this experiment is small, how do you adjust the above sonometer setup in a suitable manner to obtain a reasonably large resonant length for the given tuning fork.

.....

(h) When $M = 3.2$ kg and $f = 320$ Hz the resonant length was found to be 25.0 cm. Find the mass per unit length of the wire in kg m^{-1} .

.....

4. An experiment can be designed to determine the internal resistance r_0 of a voltmeter V using the setup shown in the figure (1).

E_0 is the e.m.f. of a cell with a certain internal resistance. R_0 is a fixed resistance and R is a resistance connected across X and Y . Assume that the ammeter A has negligible internal resistance.

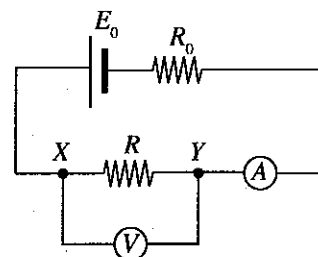

Figure (1)

(a) When the voltmeter is connected across XY as shown in the figure (1),

(i) draw below the relevant part of the circuit to show as to how the resistances R and r_0 appear across the points X and Y using circuit-symbols.



(ii) write down an expression for the equivalent resistance R_{XY} across X and Y in terms of r_0 and R .

.....

(b) The voltmeter now appears to have been connected across R_{XY} . Under this situation, will the reading of the voltmeter be equal to the value indicated by an ideal voltmeter connected across R_{XY} ? (Yes/No). Justify your answer.

.....

(c) If V is the reading of the voltmeter and I is the current through the ammeter, write down an expression for I in terms of V , r_0 and R .

.....

[see page seven

Agaram.LK - Keep your dreams alive!

Agaram.LK - Keep your dreams alive!

Do not write in this column

(d) Rearrange the expression given in (c) to plot a graph of $\frac{I}{V}$ on the y-axis and $\frac{1}{R}$ on the x-axis.

.....

.....

.....

(e) Draw the shape of the graph expected in (d) above, on the set of axes given below.

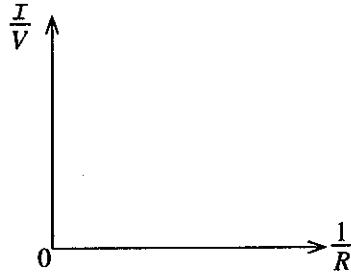

(f) Write down an expression relating r_0 , and the relevant information extracted from the graph.

.....

.....

(g) If you are asked to perform an experiment in the laboratory, and plot the graph mentioned in (e) above, name the item which you would use for R .

.....

(h) Suppose the resistance R_0 is now removed from the circuit shown in figure (1). Assume that $r_0 = 1000 \Omega$. Consider the magnitudes of the following **voltages**.

- The reading of the voltmeter (say V_1)
- The voltage generated across XY when the voltmeter is removed from the circuit (say V_2).
- If a digital multimeter having an internal resistance $10M\Omega$, is now connected across XY , the reading of the multimeter (say V_3)

Write down E_0 , V_1 , V_2 and V_3 in the ascending order according to their magnitudes.

.....

* *



[see page eight



agaram.lk

සියලු ම හිමිකම් ඇවිරිණි / முழுப் பதிப்புரிமையுடையது / All Rights Reserved

ශ්‍රී ලංකා විභාග දෙපාර්තමේන්තුව ශ්‍රී ලංකා විභාග දෙපාර්තමේන්තුව ශ්‍රී ලංකා විභාග දෙපාර්තමේන්තුව ශ්‍රී ලංකා විභාග දෙපාර්තමේන්තුව ශ්‍රී ලංකා විභාග දෙපාර්තමේන්තුව
 இலங்கைப் பரீட்சைத் திணைக்களம் இலங்கைப் பரීட்சைத் திணைக்களம் இலங்கைப் பரීட்சைத் திணைக்களம் இலங்கைப் பரීட்சைத் திணைக்களம் இலங்கைப் பரීட்சைத் திணைக்களம்
 Department of Examinations, Sri Lanka Department of Examinations, Sri Lanka Department of Examinations, Sri Lanka Department of Examinations, Sri Lanka Department of Examinations, Sri Lanka
 இலங்கைப் பரීட்சைத் திணைக்களம் இலங்கைப் பரීட்சைத் திணைக்களம் இலங்கைப் பரීட்சைத் திணைக்களம் இலங்கைப் பரීட்சைத் திணைக்களம் இலங்கைப் பரීட்சைத் திணைக்களம்
 Department of Examinations, Sri Lanka Department of Examinations, Sri Lanka Department of Examinations, Sri Lanka Department of Examinations, Sri Lanka Department of Examinations, Sri Lanka

අධ්‍යයන පොදු කෘතීම පත්‍ර (උසස් පෙළ) විභාග, 2017 අගෝස්තු
 கல்விப் பொதுத் தராதரப் பத்திர (உயர் தர)ப் பரீட்சை, 2017 அகஸ்து
 General Certificate of Education (Adv. Level) Examination, August 2017

භෞතික විද්‍යාව II
 பொளதிகவியல் II
 Physics II

01 E II

PART B – Essay

Answer four questions only.

(Acceleration due to gravity $g = 10 \text{ N kg}^{-1}$)

5. The 'pile-driver' is a heavy weight which is used to drive poles called piles into the ground for use as foundations of buildings and other structures. As shown in the figure (1), the pile-driver is lifted up by a cable and then dropped so that it falls freely under gravity and strikes the top of the pole. This process is repeated until the pole is pushed to the desired depth into the ground.

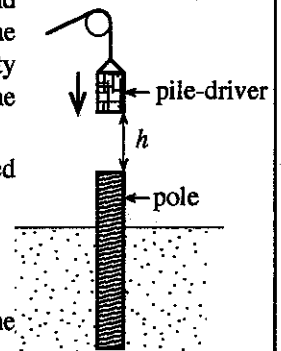

Figure (1)

(a) Consider a situation where a pile-driver of mass $M = 800 \text{ kg}$ is raised and then released from rest on to a vertical cylindrical pole of mass $m = 2400 \text{ kg}$ from a height $h = 5 \text{ m}$.

- (i) State the energy conversion that takes place during the fall of pile-driver.
- (ii) Calculate the speed of the pile-driver just before the collision.
- (iii) Calculate the magnitude of the momentum of the pile-driver just before the collision.

(b) Assume that after collision between the pile-driver and the top of the pole, the pile-driver does not bounce back, instead it remains in contact with the pole and drives the pole into the ground vertically. Also assume just after the collision, only the momentum is conserved in the system. Calculate, the following.

- (i) The speed of the pile-driver with pole just after the collision.
- (ii) The kinetic energy of the pile-driver with pole just after the collision.
- (iii) In each collision 40% of the energy calculated in (b)(ii) is used usefully to drive the pole into the ground. If in one particular collision it drives the pole 0.2 m into the ground, calculate the average resistive force acting on the pole.

(c) Consider a situation where a uniform cylindrical wooden pole of 10m height and 0.3 m radius is pushed entirely into a sandy soil as shown in the figure (2). The maximum load F the pole can hold when keeping it as shown in figure (2) could be written as $F = A_s f_s + A_b f_b - W$,

where W is the weight of the pole, A_s is the area of the curved surface of the pole which is in contact with the soil, f_s is the average resistive force on the curved surface of the pole per unit area, A_b is the cross sectional area of the base of the pole and f_b is the average resistive force from the ground on the base of the pole per unit area.

If $f_s = 5 \times 10^4 \text{ N m}^{-2}$, $f_b = 2 \times 10^6 \text{ N m}^{-2}$ and the density of the wood is $8 \times 10^2 \text{ kg m}^{-3}$, calculate the value of F for the pole. Take the value of π as 3.

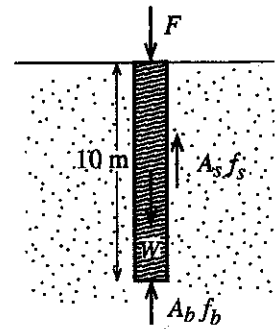

Figure (2)

(d) System of four poles, each similar to the pole used in (c) but having a radius equal to half of the radius of the pole used in (c), is pushed entirely into a sandy soil. This is shown in the figure (3) when seen from the above.

- (i) As given in (c) above, the F has three components as $A_s f_s$, $A_b f_b$ and W . When using the system of four poles for a construction, which component of the F , for the system of four poles, is contributing to increase its value in compared with the situation considered in (c) above.
- (ii) Calculate the value of F for the system of four poles.

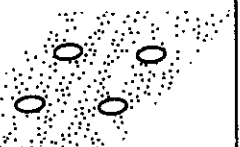

Figure (3)

6244

6. (a) (i) A thin convex lens of focal length f is used as a simple microscope. Draw a ray diagram for a situation when a distinct image is seen using the simple microscope by a person having the least distance of distinct vision D . Clearly mark the positions of the eye, f and D .
- (ii) Derive an expression for the linear magnification of a simple microscope in terms of f and D .
- (iii) A thin convex lens of focal length 10 cm is used by the person mentioned in (i) above as a simple microscope to read very small letters. To see the clear image of a letter, what would be the distance from the lens to the letter. Calculate the linear magnification of the simple microscope. Take the value of D as 25 cm.
- (iv) A historical document placed in a museum is framed using a transparent glass plate of 2 cm thickness to protect it. Assume that the inner surface of the glass plate touches the document. Take the refractive index of glass as 1.6. Find the distance to the apparent position of the document from the front surface of the glass plate.
- (v) Consider that the same person mentioned in part (i) is reading the document using the simple microscope mentioned in part (iii).
- (1) What is the distance from the lens, to the image of the document produced by the lens when the letters are clearly seen by the person?
- (2) What is the distance to the document from the lens when the letters in the document are clearly seen?
- (b) (i) Draw a **complete** ray diagram indicating all relevant lengths for an astronomical telescope in normal adjustment labelling the objective and the eyepiece clearly. Take f_o and f_e as the focal lengths of the objective and the eyepiece respectively.
- (ii) Derive an expression for the angular magnification of the telescope when it is in normal adjustment using the ray diagram drawn in part (b)(i).
- (iii) An astronomical telescope is made using two thin convex lenses of focal lengths 100 cm and 10 cm. Calculate the angular magnification of the telescope in normal adjustment.
- (iv) What is the practical advantage of using a convex lens with large aperture area as the objective of an astronomical telescope? Explain your answer.

7. Read the following passage and answer the questions.

Instability of soil that occurs due to the infrastructure developments such as road constructions in mountain regions without proper study, can create problems such as sinking roads and landslides. Landslides are now a common tragedy in many parts of the country during rainy seasons. The stability of sand, a constituent of soil, heavily depends on the amount of water present in the sand. Anyone who has built structures such as 'sandcastles' using wet sand knows that the adhesive properties of wet and dry sand are very different. Wet sand can be used to build sharp-featured sandcastles whereas dry sand just crumbles down in this process. Some of the aspects of these phenomena related to the stability of soil or sand can be explained by fundamental physics concepts such as gravity, friction and surface tension.

Soil is generally a porous medium comprising a mixture of mineral particles such as clay, silt and sand of different sizes, and voids. Voids are filled with either air or water as shown in figure 1(a). The porous nature of soil can create practical problems, such as sinking of heavy structures on the ground. This occurs due to the compression of voids caused by the heavy loads on the ground. Leaning of Pisa tower and sinking of the Meethotamulla dump site and the earth in the vicinity of the Uma Oya tunnel are a few examples. Another important parameter which determines the stability of soil (or sand) is the angle of repose. When a bucket of dry soil is emptied on to a hard levelled floor the soil particles slide easily and form a conical pile due to the friction between grains as shown in figure (2). The angle α of the pile is known as the angle of repose which is the steepest stable slope that a particular substance can form. Removal of soil from the base of a slope, increasing the angle of repose, can create instability on the slope.

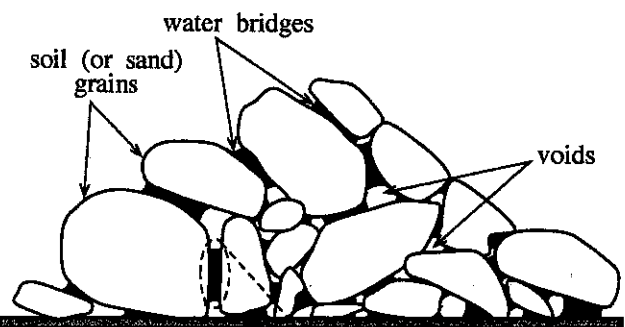

Figure 1(a)

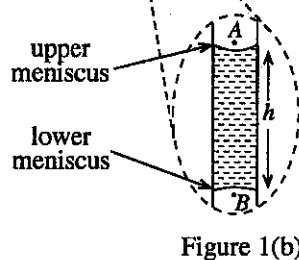

Figure 1(b)

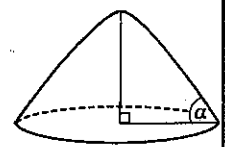

Figure (2)

Sand in soil can be considered as a porous medium. It consists of a system of randomly oriented complex capillary tubes of different sizes similar to the structure shown in figure 1(a). Capillary forces draw water into the sand changing the physical properties of sand medium. Damp sand forms capillary water bridges between its grains (see figure 1(a)). Nanometre-scale water bridges between millimetre-scale grains dramatically increase the attraction between grains. It is due to the adhesive forces associated with the water bridges between grains. Dry sand grains maintain stability due to frictional forces, and in addition wet sand grains attract each other due to adhesive forces. The enhancement of the attraction of the grains due to these capillary forces leads to the increase of the repose angle creating sand clumps. The surface of a water bridge is concave (figure 1(b)), and so generates 'capillary action' which helps to hold the sand grains firmly together due to surface tension.

During rainy season the soil saturated with water creates high pressure on the voids and grains. Gradually increasing the pressure inside voids increases the curvature of the surface of water bridges decreasing the capillary force between the grains. The addition of more water to the soil can decrease friction and strength between the grains, and increase the weight of the soil making an ideal situation for landslides. Damage on the Earth's soil surface due to the addition of large amounts of pesticides and fertilizers decreasing the surface tension force between the grains can also dramatically increase the likelihood of a landslide.

(a) Name **three** fundamental physics concepts which can be used to explain some aspect of the stability of soil and sand.

(b) Write down **three** main mineral constituents of soil.

(c) In a road construction, soil has been removed from a certain section of the slope altering the natural slope as shown in figure (3). This is a vulnerable place for landslides. Explain this using the information given in the passage.

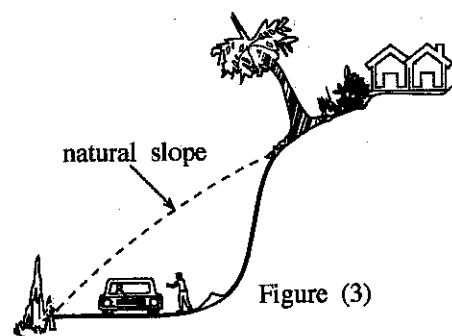

Figure (3)

(d) Addition of water into dry sand dramatically increases the stability of sand. Explain the main reason for this.

(e) A water bridge between two spherical sand grains is shown in figure (4). Copy the figure (4) to your answer script and draw the **resultant** reaction forces (using arrows) **on each grain** due to the surface tension.

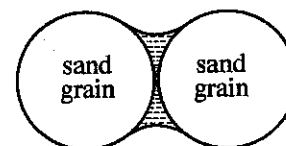

Figure (4)

(f) Consider a water bridge formed by two sand grains shown in figure 1(b) where the radii of curvature of the upper and lower menisci are r_1 and r_2 respectively. Using the expressions for the pressure differences across the upper and lower air-water interfaces, derive an expression for the height h of the water column in figure 1(b). Take surface tension and density of water as T and d respectively. Assume that the pressures at points A and B, shown in the figure, are **equal**.

(g) Calculate the height h for the situation mentioned in (f) above. Take $r_1 = 0.8$ mm, $r_2 = 1.0$ mm, $T = 7.2 \times 10^{-2}$ N m⁻¹ and $d = 1.0 \times 10^3$ kg m⁻³.

(h) Consider a situation where the pressures at points A and B are **higher** than the situation shown in figure 1(b). Copy the figure 1(b), **including the two menisci**, to your answer script and draw the shapes of the two new menisci and **clearly** label them as X and Y.

(i) If the pressures at points A and B, shown in figure 1(b), are continuously increasing, what will happen to the radii of the menisci, contact angle and the resultant reaction forces due to the surface tension forces between the grains? Explain your answer.

(j) Write down **two** human activities mentioned in the passage, which can increase the likelihood of landslides.

8. The main objective of NASA's Kepler exploration is to find habitable planets in other planetary systems in our galaxy, the Milky Way. A large number of planets which orbit around stars have been detected by the exploration. One such observation was a planetary system consisting of two planets, planet A and planet B of orbital periods $T_A = 300$ earth days and $T_B = 50$ earth days, respectively. Assume that the planets are uniform spheres and moving in circular orbits around a star S of mass M as shown in the figure. Neglect the interaction between the planets.

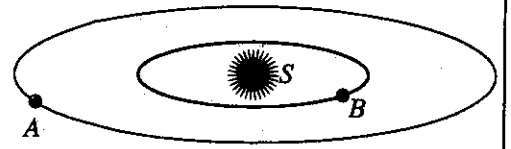

- (a) (i) Derive an expression for the orbital speed (v_B) of the planet B in terms of M , the orbital radius R_B of the planet B and universal gravitational constant G .
- (ii) Write down an expression for the period T_B of the planet B in terms of R_B and v_B .
- (iii) Derive an expression for the mass M of the star at the centre in terms of T_B , R_B and G .
- (iv) If $R_B = 0.3 \text{ AU}$ ($1 \text{ AU} = 1.5 \times 10^{11} \text{ m}$), calculate the mass M of the star. Take $G = 6.7 \times 10^{-11} \text{ m}^3 \text{ kg}^{-1} \text{ s}^{-2}$ and $\pi^2 = 10$.
- (b) (i) Using the expression obtained in (a)(iii) above, derive an expression relating orbital radii R_A , R_B and periods T_A and T_B of planets A and B.
- (ii) Calculate the orbital radius R_A of planet A using given values.
- (c) The mass and the radius of the outer planet A are found to be $23 m_E$ and $4.6 r_E$ respectively, where m_E and r_E are the mass and the radius of the earth respectively.
- (i) Derive an expression for the gravitational acceleration, g_A , at a point on the surface of planet A, in terms of m_E , r_E and G .
- (ii) Obtain an expression for the g_A in terms of the gravitational acceleration g_E at a point on the surface of the earth.
- (iii) If a space landing module of mass 100 kg is landed on planet A, calculate the weight of the landing module after landing.
- (iv) The outer planet A is located within the habitable zone when compared with our solar system. Obtain an expression for the average density d_A of the planet A in terms of the average density d_E of earth.

9. Answer either part (A) or part (B) only.

- (A) (a) Explain briefly how the back electromotive force (e.m.f.) is produced in a direct current motor. Name the laws in physics which determine (i) the magnitude and (ii) the direction of the back e.m.f. respectively.
- (b) Write down an expression for the back e.m.f. E produced by a direct current motor when it draws a current of I from a battery. The internal resistance of the motor coil is r and the terminal voltage of the battery is V .
- (c) If $V = 80 \text{ V}$ and $r = 1.5 \Omega$ calculate the following quantities when the motor operates with full load drawing a current of 4.0 A.
- (i) Back e.m.f. (E) produced by the motor.
- (ii) Power given to the motor.
- (iii) The mechanical power output and the efficiency of the motor. (Neglect any energy losses due to friction.)
- (d) Assume that the values given for r and the current (4.0 A) in (c) above for the motor are the values when the coil is at the room temperature of 30°C . After running the motor for several hours it was found that the current in the coil had dropped to 3.6 A with voltage V remaining unaltered at 80 V. Calculate the new temperature of the coil. Temperature coefficient of resistance of the material of the coil is $0.004^\circ \text{C}^{-1}$ at 0°C .
- (e) In electric motor vehicles, direct current motors driven by batteries are used to rotate the wheels of the vehicles. During the application of brakes, the same motor in such vehicles is made to operate as a direct current generator, and part of the kinetic energy of the vehicle is used to drive the generator. The generator output is then used to recharge the battery of the same vehicle.
- (i) How do you operate a direct current motor as a direct current generator?
- (ii) Copy the two diagrams in the figure to your answer script and show how you would connect the direct current generator output to charge the battery.

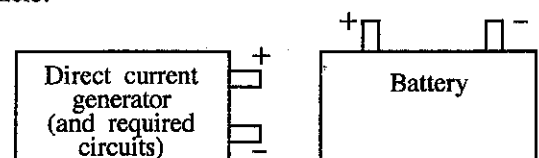

(B) (a) Write down the expression for the relationship among I_C , I_E and I_B of an *npn* transistor. All symbols have their usual meaning.

(b) The *npn* transistor connected as shown in figure (1), is operating in the active mode. Assume that the current gain of the transistor is 100, and when it is forward biased, the voltage across the base and the emitter, $V_{BE} = 0.7\text{V}$.

(i) Calculate the base current I_B necessary to produce a collector voltage of 5V.

(ii) Calculate the value of R_2 if $R_1 = 12\text{k}\Omega$. (Assume I_B is negligible for this calculation).

(iii) Modify the given circuit shown in figure (1) so that it could be operated with a negative power supply voltage of -10V . Correctly re-label, the modified circuit using R_1 , R_2 , $10\text{k}\Omega$, and the labels A and B given for the points in the **appropriate** manner. Indicate the direction of the collector current, and the direction of the current through R_1 and R_2 with arrows.

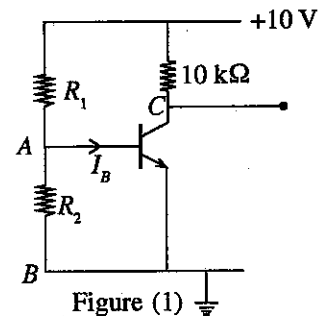

Figure (1)

(c) A photodiode is to be connected across the base and the emitter of the transistor in the **modified circuit** that you have drawn under (b)(iii).

(i) When connecting a photodiode to a circuit, it is done in such a way that the photodiode is reverse biased. Using the circuit symbol of the photodiode show how you would connect it correctly across the base and the emitter of the transistor in the **modified circuit**.

(ii) When the photodiode is connected to the modified circuit correctly, will it alter the resistance across base and emitter appreciably? Explain your answer.

(iii) When a rectangular light pulse of short duration is incident on the photodiode,

(1) show the direction of the current through the photodiode in the circuit using an arrow.

(2) draw the waveform of the **voltage** pulse appearing at the base relative to emitter, and the waveform of the **voltage** pulse at the collector relative to the earth due to the light pulse at appropriate places on the circuit.

10. Answer either part (A) or part (B) only.

(A) A certain house consumes 100 kg of hot water at 50°C per one hour for washing purposes at the kitchen and bath rooms. Hot water generated at 70°C by an electrical boiler is mixed outside the boiler with water at 30°C to produce water at 50°C .

Take specific heat capacity, and the density of water as $4200\text{J kg}^{-1}\text{K}^{-1}$ and 1000kg m^{-3} respectively.

Assume that the heat loss to surroundings and the heat capacity of the boiler are negligible for all the calculations.

(a) Calculate the mass of hot water to be needed from the boiler at 70°C to produce 100 kg of water at 50°C .

(b) The boiler is designed so that when the amount of hot water at 70°C calculated in (a) is taken out of the boiler it is refilled with the same amount of water at 30°C in such a way that the temperature of the water inside the boiler does not go below 66°C . Calculate the minimum capacity of water of the boiler in terms of (i) kilograms and (ii) litres needed to fulfil this condition.

(c) At the beginning of the day, the boiler is filled with the same amount of mass of the water calculated in (b) as the capacity, and heated at a constant rate from 30°C to 70°C using an electrical heater. If the heating is to be completed in one hour, calculate the power of the heater needed for this purpose.

(d) After the initial heating has been done according to (c), refilling of water at 30°C is done continuously to compensate for the hot water taken out of the boiler according to the requirement (a) above. The boiler is designed so that another small electric heater provides heat to maintain the average temperature of the boiler at 70°C throughout the period of one hour. Calculate the power of the small heater needed.

- (B) (a) (i) The diagram given in figure (1) is a rough sketch of an X-ray tube. Name the parts marked as A and B.
- (ii) Name the part marked as D and explain the purpose of using it.
- (iii) Name the part marked as C in the diagram and explain the purpose of using it.
- (iv) Explain how X-rays are produced.
- (v) Give a reason for using an evacuated tube.

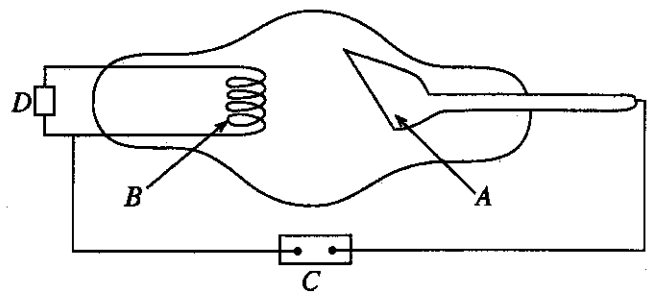

Figure (1)

- (b) The supply voltage of an X-ray tube is 100 000 V.
- (i) Calculate the maximum energy of an electron reaching A in units of keV.
- (ii) An electron carrying the maximum energy calculated in (b)(i) above produces an X-ray photon spending half of its energy, and the rest of the energy is completely absorbed. Explain what will happen to the absorbed energy.
- (iii) Calculate the wavelength of the X-ray photon produced in part (b)(ii).
 $[h = 6.6 \times 10^{-34} \text{ J s}, c = 3 \times 10^8 \text{ m s}^{-1} \text{ and } 1 \text{ eV} = 1.6 \times 10^{-19} \text{ J}]$

- (c) When γ -rays pass through a material, a certain fraction of the γ -ray photons are absorbed by the material. Consider a beam of γ -rays of intensity I_0 incident perpendicular to a sheet of material of thickness t as shown in the figure (2). As a result of the absorption the transmitted intensity of the γ -ray beam is decreased, and it is denoted by I .

The relationship between I_0 and I is given by $\log\left(\frac{I_0}{I}\right) = 0.434\mu t$, where μ is a constant for the material at the given γ -ray energy. All data given below are for 2 MeV γ -rays. Take value of μ for lead as 51.8 m^{-1} for 2 MeV γ -rays.

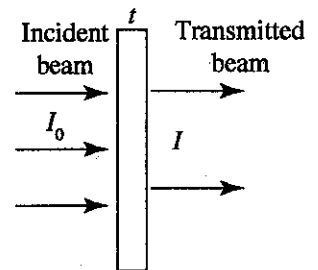

Figure (2)

- (i) Calculate the thickness of lead required to reduce the intensity of the above γ -rays by half.
- (ii) The maximum permissible annual dose for a radiation worker is 20 mSv. When a person is exposed to the above γ -ray beam of intensity $10^{10} \text{ m}^{-2} \text{ s}^{-1}$, the annual dose received is $2.5 \times 10^6 \text{ mSv}$. Determine the maximum intensity of the above beam of γ -rays that a radiation worker can be exposed without exceeding the maximum permissible dose.
- (iii) Consider a radiation therapy room in a hospital, in which a 2 MeV γ -ray source is installed to treat patients. Radiation workers work in the adjacent room. The two rooms are separated by a lead wall. In case of a radiation leak in the source the maximum intensity of the γ -rays incident normal to the lead wall is $2.56 \times 10^6 \text{ m}^{-2} \text{ s}^{-1}$. Determine the minimum thickness of the lead wall required in order for the radiation workers to work safely in their room.
