

AL/2016/66-E-I

සියලු ම හිමිකම් ඇවිරිණි / முழுப் பதிப்புரிமையுடையது / All Rights Reserved

ශ්‍රී ලංකා විභාග දෙපාර්තමේන්තුව ශ්‍රී ලංකා විභාග දෙපාර්තමේන්තුව ශ්‍රී ලංකා විභාග දෙපාර්තමේන්තුව ශ්‍රී ලංකා විභාග දෙපාර්තමේන්තුව ශ්‍රී ලංකා විභාග දෙපාර්තමේන්තුව
 இலங்கைப் பரீட்சைத் திணைக்களம் இலங்கைப் பரීட்சைத் திணைக்களம் இலங்கைப் பரීட்சைத் திணைக்களம் இலங்கைப் பரීட்சைத் திணைக்களம் இலங்கைப் பரීட்சைத் திணைக்களம்
 Department of Examinations, Sri Lanka Department of Examinations, Sri Lanka Department of Examinations, Sri Lanka Department of Examinations, Sri Lanka Department of Examinations, Sri Lanka
 இலங்கைப் பரීட்சைத் திணைக்களம் இலங்கைப் பரීட்சைத் திணைக்களம் இலங்கைப் பரීட்சைத் திணைக்களம் இலங்கைப் பரīட்சைத் திணைக்களம் இலங்கைப் பரīட்சைத் திணைக்களம்
 Department of Examinations, Sri Lanka Department of Examinations, Sri Lanka Department of Examinations, Sri Lanka Department of Examinations, Sri Lanka Department of Examinations, Sri Lanka

අධ්‍යයන පොදු කෘතීම පසු (උසස් පෙළ) විභාග, 2016 අගෝස්තු
 கல்விப் பொதுத் தராதரப் பத்திர (உயர் தர)ப் பரீட்சை, 2016 ஆகஸ்ட்
 General Certificate of Education (Adv. Level) Examination, August 2016

ජෛවපද්ධති තාක්ෂණවේදය I
 உயிரமுறைமைகள் தொழினுட்பவியல் I
 Biosystems Technology I

66 E I

පැය දෙකයි
 இரண்டு மணித்தியாலம்
 Two hours

Instructions:

- * Answer all the questions.
- * Write your Index Number in the space provided in the answer sheet.
- * Instructions are given on the back of the answer sheet. Follow them carefully.
- * In each of the questions 1 to 50, pick one of the alternatives from (1), (2), (3), (4), (5) which is correct or most appropriate and mark your response on the answer sheet with a cross (×) in accordance with the instructions given at the back of the answer sheet.
- * Use of calculators is not allowed.

1. Methods of food preservation used since ancient times are
 - (1) freezing and boiling.
 - (2) canning and blanching.
 - (3) drying and fermenting.
 - (4) irradiation and smoking.
 - (5) pasteurization and sterilization.
2. The growing of plants by suspending their roots in the air and spraying them with nutrient solutions is known as
 - (1) fogponics.
 - (2) geoponics.
 - (3) aeroponics.
 - (4) aquaponics.
 - (5) hydroponics.
3. Lath houses are mainly used to
 - (1) train foliage plants.
 - (2) germinate dormant seeds.
 - (3) promote rooting of cuttings.
 - (4) protect plants from pests and diseases.
 - (5) enhance flowering in cut flower industry.
4. Use of certified seeds is considered as a method of
 - (1) cultural weed control.
 - (2) biological weed control.
 - (3) chemical weed control.
 - (4) mechanical weed control.
 - (5) preventative weed control.
5. The most appropriate action to be taken to minimize the air pollution in broiler industry is
 - (1) raking the litter at weekly intervals.
 - (2) the use of close house system.
 - (3) introduction of exhaust fans.
 - (4) the use of suitable litter material.
 - (5) preventing water spill and leakage in drinkers.
6. Heat synchronization is mainly used for
 - (1) calves.
 - (2) dry cows.
 - (3) stud bulls.
 - (4) cows with breeding irregularities.
 - (5) non-pregnant cows.
7. In a weather station,
 - (1) non-recording type rain gauges record intensity of a rainfall.
 - (2) non-recording type rain gauges record duration of a rainfall.
 - (3) recording type rain gauges record the type of a rainfall.
 - (4) non-recording type rain gauges record the total amount of a rainfall.
 - (5) recording type rain gauges are only used to record intensity of a rainfall.
8. The most suitable direct water source for a food processing factory is
 - (1) river water.
 - (2) shallow well water.
 - (3) class I groundwater.
 - (4) class III groundwater.
 - (5) class IV groundwater.

[See page two]

9. The most common aquarium fish species exported from Sri Lanka is
 (1) Guppy. (2) Cat fish. (3) Gold fish. (4) Angel fish. (5) Sword tail fish.
10. The highest contribution to the marine fish industry in Sri Lanka is provided by
 (1) Eastern province. (2) Western province. (3) Southern province.
 (4) Northern province. (5) North Western province.
11. The main feature of biomass fuel is that
 (1) it is non renewable.
 (2) it is always of inorganic origin.
 (3) it is less geographically distributed.
 (4) it emits more pollutants than fossil fuel.
 (5) it does not contribute to increase the atmospheric CO₂ level.
12. A computer operator suffers from back pain due to the long term use of incorrect posture. This situation can be best described as
 (1) a labour hazard. (2) a physical hazard. (3) a chemical hazard.
 (4) a biological hazard. (5) a psychosocial hazard.
13. Following are some statements on certain soil characteristics.
 A - Addition of organic matter to a soil, alters the structure of the soil.
 B - Compaction of a soil, changes the texture of the soil.
 C - Compaction of a soil, increases the bulk density of the soil.

Of the above, the correct statement/s would be

- (1) A only. (2) B only. (3) C only.
 (4) A and B only. (5) A and C only.
14. Porosity of a soil
 (1) increases with the increase in the bulk density of soil.
 (2) increases with the decrease in the bulk density of soil.
 (3) increases with the increase in the coarseness of soil particles.
 (4) is the total pore volume of a soil in relation to the oven dried mass of a soil.
 (5) is the total pore volume of a soil in relation to the total volume of only solids.
15. Following are some statements on mechanical soil conservation methods.
 A - Prevent impacts of rain drops.
 B - Safely drain the runoff.
 C - relatively cheaper to install in the field.

Of the above, the correct statement/s would be

- (1) A only. (2) B only. (3) C only.
 (4) A and B only. (5) A and C only.
- The following diagram shows the staff readings of three locations A, B and C of a land using a dumpy level. Use the following diagram to answer the question No. 16.

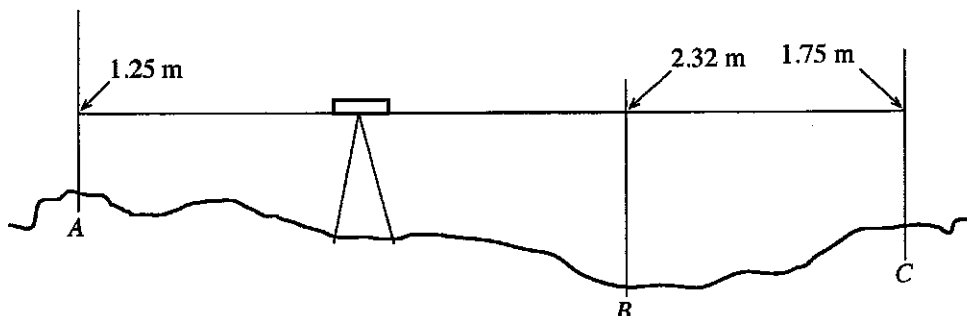

16. The elevation difference between A and C is
 (1) 0.50 m (2) 0.57 m (3) 1.07 m (4) 3.00 m (5) 3.57 m

17. For grafting, the scion should be taken from a mother plant having a

- A - well developed root system.
- B - well spread canopy.
- C - high yield with good quality.

Of the above, the correct statement/s would be

- (1) A only.
- (2) B only.
- (3) C only.
- (4) A and B only.
- (5) B and C only.

18. Following are several statements about obtaining the SLS certification for food products in Sri Lanka.

- A - The company should agree to pay 5% of their annual income to the Sri Lanka Standard Institute.
- B - The quality of the food products should be confirmed by standard quality management system available in the factory.
- C - If the factory is using the imported raw materials, SLS certification can be obtained without any test.

Of the above, the correct statement/s would be

- (1) A only.
- (2) B only.
- (3) C only.
- (4) A and B only.
- (5) B and C only.

19. Harvesting at proper maturity level increases

- (1) shelf life of the harvest.
- (2) germination of seeds inside the pods.
- (3) the fibre content of harvest.
- (4) the grain shedding in cereals.
- (5) the colour, odour and flavour of harvest.

20. Following are some statements on harvesting of certain crops.

- A - Best time to harvest leafy vegetables is the late evening.
- B - It is suitable to harvest mango by cutting at the upper end of the petiole of the fruit.
- C - The most suitable time to harvest citrus fruits is morning.

Of the above, the correct statement/s would be

- (1) A only.
- (2) B only.
- (3) C only.
- (4) A and B only.
- (5) A and C only.

21. Vacuum packaging is considered as one of the best packaging systems used in food industry. In vacuum packaging, the most important is the maintaining of

- (1) 0% air and 0% moisture inside the package.
- (2) 0% air and 15% moisture inside the package.
- (3) 25% air and 0% moisture inside the package.
- (4) 25% air and 25% moisture inside the package.
- (5) 50% air and 50% moisture inside the package.

22. A particular company has planned to introduce a new product for those suffering from Diabetes Mellitus.

This new product should contain

- (1) less amount of fibre.
- (2) high amount of fibre.
- (3) high amount of trans fat.
- (4) high amount of simple carbohydrates.
- (5) considerable amount of complex carbohydrates.

23. Sensory evaluation can be used to

- (1) determine the shelf life of a food product.
- (2) analyse the major nutrients of a food product.
- (3) improve the nutritional value of a food product.
- (4) decrease the production cost of a food product.
- (5) assure the raw material quality of a food product.

24. The carbohydrate content of a food product can be determined by

- (1) Kejeldhal method.
- (2) Dye binding method.
- (3) Lane and Eynon method.
- (4) Formol titration method.
- (5) Soxhlet extraction method.

- Use following diagram to answer question No. 25.

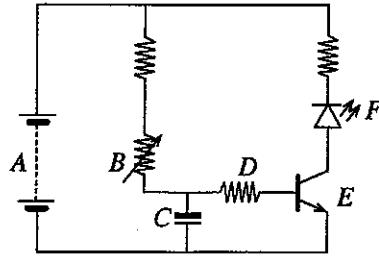

25. Of the above diagram A, B, C, D, E and F are,
- (1) Capacitor, battery, transistor, diode, IC and a LED respectively.
 - (2) Battery, resistor, capacitor, transistor, diode and a LED respectively.
 - (3) Capacitor, LED, variable resistor, resistor, transistor and a diode respectively.
 - (4) Capacitor, resistor, battery, variable resistor, transistor and a LED respectively.
 - (5) Battery, variable resistor, capacitor, resistor, transistor and a LED respectively.
26. Electronic controller of an automatic irrigation system would
- (1) calculate the water holding capacity of soil.
 - (2) measure the temperature of irrigation water.
 - (3) measure the moisture content of soil without a sensor.
 - (4) send an output signal to the moisture sensor for commencing irrigation.
 - (5) send an output signal to open valves for irrigation when necessary.
27. Example for a closed loop control system is
- (1) a valve open by a timer.
 - (2) a light switch-on manually.
 - (3) temperature controller of an egg incubator.
 - (4) a DC motor operated by a battery.
 - (5) a timer to activate an irrigation system.
28. In a water treatment plant, a part of secondary sludge is returned back to secondary treatment unit to
- (1) quicken the coagulation and flocculation.
 - (2) introduce more oxygen to the treatment unit.
 - (3) treat further in the secondary treatment unit.
 - (4) introduce more bacteria to the treatment unit.
 - (5) make the sedimentation process more efficient.
- Use the following diagram of a water pump to answer question No. 29.

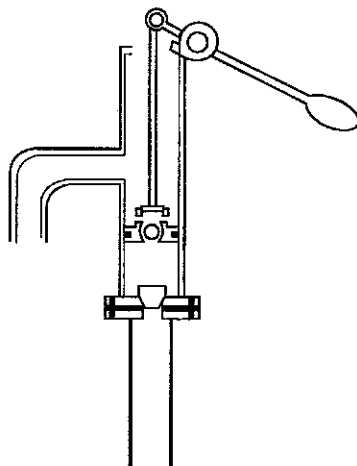

29. The above water pump is
- (1) a gear pump.
 - (2) a centrifugal pump.
 - (3) a roto-dynamic pump.
 - (4) a non-self priming pump.
 - (5) a positive displacement pump.

[See page five

- Following graph shows the patterns of monthly precipitation and evapotranspiration in a particular field in the year 2015. Use this graph to answer the question No. 30.

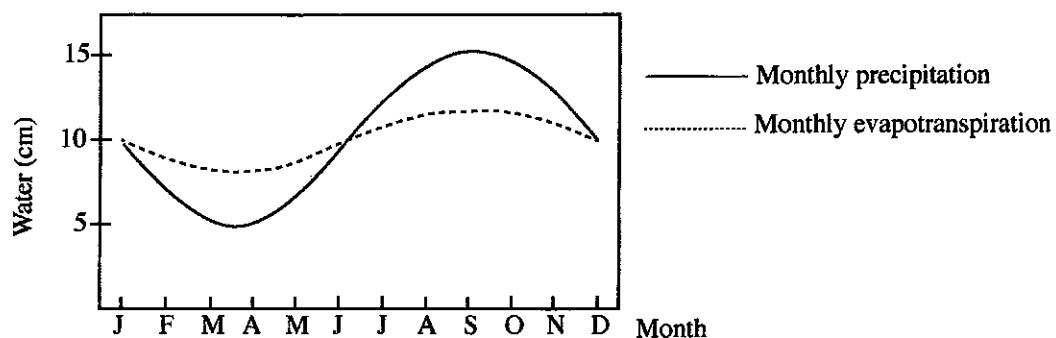

30. According to the above graph, this field should be irrigated from
- (1) January to May. (2) February to June. (3) March to September.
 (4) June to December. (5) September to December.
31. A farmer diverted a water stream of 135 litres per second to his crop field via a canal. When he measured the amount of water received to his field, he found only 100 litres per second reaches the field. The conveyance efficiency of this irrigation system is
- (1) 50%. (2) 60%. (3) 64%. (4) 74%. (5) 135%.
32. A typical drip irrigation system consists of
- (1) pump unit, pressure regulator, laterals, raised pipes and emitters.
 (2) pump unit, pressure regulator, main lines, sub-main lines, laterals and emitters.
 (3) pump unit, filters, pressure regulator, pipe lines, laterals, couplers and emitters.
 (4) pump unit, pressure regulator, pressure gauge, main lines, couplers and laterals.
 (5) pump unit, storage tank, main lines, sub-main lines, laterals and sprinkler heads.
33. Integrated pest management
- (1) is a traditional pest control method.
 (2) is a system approach using multiple strategies.
 (3) promotes a single strategy for all the pest problems.
 (4) is the most cost-effective means of destroying pests.
 (5) mainly focuses its strategies on biological control measures.
- Use the following diagram to answer question No. 34.

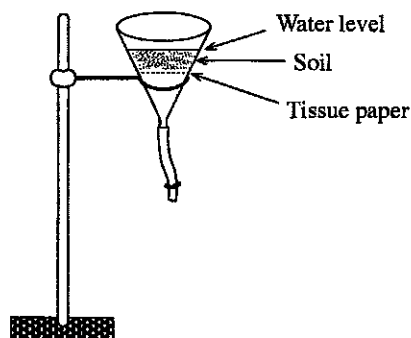

34. In plant pest management, the above set-up is mainly used to separate and count
- (1) soil born bacteria. (2) free-living nematodes.
 (3) weed seeds found in the soil. (4) fungal spores found in the soil.
 (5) egg masses of pests found in the soil.
35. Following are two statements regarding artificial insemination.
- A - Artificial insemination is the most successful method to produce best quality offspring in cattle breeding in Sri Lanka.
 B - Only the best quality bulls from different breeds are used for semen collection.
- Of the above statements,
- (1) A is correct. (2) B is correct.
 (3) Both A and B are correct. (4) A is correct and B further explains A.
 (5) B is correct and A further explains B.

[See page six

36. Following are certain parameters measured in milk.

- A - Fat percentage B - Solid non-fat percentage
C - Specific gravity

Of the above, the price of the milk at collecting centres in Sri Lanka is determined by

- (1) A only. (2) B only. (3) A and B only.
(4) A and C only. (5) All A, B and C.

37. The most critical issue in the eco-tourism sector in Sri Lanka is

- (1) high cost.
(2) limited number of eco-tourism sites.
(3) limitations in communication facilities.
(4) less developed international travel network.
(5) poor road network to reach attractive places.

38. Freezing is considered as one of the main food preservation techniques. Freezing, always

- (1) removes the moisture from the food.
(2) immobilizes the water within the food.
(3) destroys the enzyme available in the food.
(4) increases the nutritional value of a food.
(5) extends the shelf-life of a food up to one year.

39. In plant nursery management,

- (1) shading should be increased continuously to harden plants.
(2) organic fertilizer could be supplied through irrigation water.
(3) irrigation interval should be decreased to harden plants.
(4) a drip irrigation system with low water discharge rate could be used.
(5) a sprinkler irrigation system with high water discharge rate could be used.

40. Several statements about poultry housing are stated below.

- A - The long axis of the poultry house should be oriented East-West direction.
B - The amount of direct sunlight enter into the poultry house should be minimized.
C - The height of the side brick wall should be about 30cm.

Of the above statements,

- (1) only A and B are correct and A explains B.
(2) only B and C are correct and C explains B.
(3) only B and C are correct and B explains C.
(4) all A, B and C are correct and A explains B.
(5) all A, B and C are correct and B explains A.

41. In landscaping, hedgerow is commonly used to form

- (1) a circle. (2) a path. (3) a polder. (4) a matrix. (5) a corridor.

● Use the following diagram of symbol to answer the question No. 42.

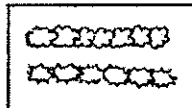

42. Various symbols are used to indicate different components in a landscape design. In landscaping designs, this symbol represents

- (1) trees. (2) fence. (3) hedge. (4) bushes. (5) a foot path.

43. The most suitable grass type for a school playground is

- (1) Blue grass. (2) Malaysian grass. (3) Guinea grass. (4) Buffalo grass. (5) Elephant grass.

- Use the following diagram to answer question No. 44.

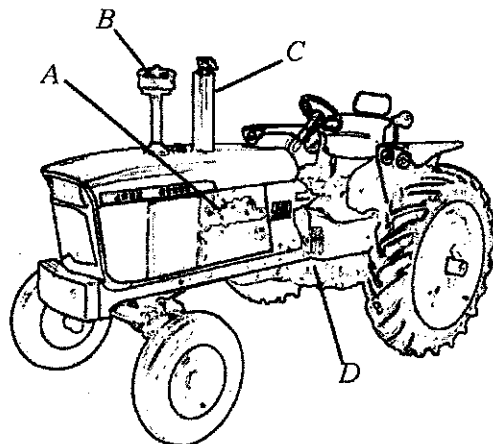

44. A, B, C and D of the above tractor are
- (1) engine, air cleaner, silencer and gear box respectively.
 - (2) gear box, silencer, air cleaner and engine respectively.
 - (3) gear box, air cleaner, silencer and engine respectively.
 - (4) silencer, air cleaner, radiator and gear box respectively.
 - (5) air cleaner, silencer, gear lever and engine respectively.
45. Depth of ploughing by disk plough mounted on a four wheel tractor is controlled by the
- (1) gear ratio.
 - (2) engine rpm.
 - (3) draught controller.
 - (4) three point linkage.
 - (5) air pressure of rear wheels.
46. A technical officer obtained a lightly wet soil sample from a site, squeezed, threw it to the air to the height of about 2m and then carefully observed the falling sample. The objective of this test is to determine
- (1) the time of irrigation.
 - (2) the water holding capacity of soil.
 - (3) the suitable crop types for the site.
 - (4) the suitability for establishing a fish pond.
 - (5) a method of irrigation for the site.
47. In a conservation forest
- (1) collection of firewood is allowed.
 - (2) only research activities are allowed.
 - (3) only tourism and research activities are allowed.
 - (4) any kind of activity is strictly prohibited.
 - (5) collection of non-timber forest products is allowed.
48. Following are some plant related products.
- | | |
|-----------------|------------------|
| A - Coconut oil | B - Rubber latex |
| C - Pinus resin | D - Cashew resin |
- Of the above, example/s for plant exudates would be
- (1) A only.
 - (2) B only.
 - (3) C only.
 - (4) A and B only.
 - (5) B, C and D only.
49. Major characteristics of the plant extract to be extracted using organic solvents are
- (1) high heat stability and high polarity.
 - (2) low heat stability and low water solubility.
 - (3) high heat stability and low water solubility.
 - (4) low heat stability and high water solubility.
 - (5) high heat stability and high water solubility.
50. Examples for entrepreneurial skills are
- (1) creativity and writing ability.
 - (2) creativity and readiness to take risks.
 - (3) environmental sensitivity and writing ability.
 - (4) readiness to take risks and voice modulation.
 - (5) environmental sensitivity and voice modulation.



agaram.lk

AL/2016/66-E-II

සියලු ම හිමිකම් ඇවිරිණි / முழுப் பதிப்புரிமையுடையது / All Rights Reserved

ශ්‍රී ලංකා විභාග දෙපාර්තමේන්තුව ශ්‍රී ලංකා විභාග දෙපාර්තමේන්තුව ශ්‍රී ලංකා විභාග දෙපාර්තමේන්තුව ශ්‍රී ලංකා විභාග දෙපාර්තමේන්තුව ශ්‍රී ලංකා විභාග දෙපාර්තමේන්තුව
 இலங்கைப் பரீட்சைத் திணைக்களம் இலங்கைப் பரීட்சைத் திணைக்களம் இலங்கைப் பரීட்சைத் திணைக்களம் இலங்கைப் பரීட்சைத் திணைக்களம் இலங்கைப் பரීட்சைத் திணைக்களம்
 Department of Examinations, Sri Lanka Department of Examinations, Sri Lanka Department of Examinations, Sri Lanka Department of Examinations, Sri Lanka Department of Examinations, Sri Lanka
 இலங்கைப் பரීட்சைத் திணைக்களம் இலங்கைப் பரීட்சைத் திணைக்களம் இலங்கைப் பரීட்சைத் திணைக்களம் இலங்கைப் பரීட்சைத் திணைக்களம் இலங்கைப் பரීட்சைத் திணைக்களம்
 Department of Examinations, Sri Lanka Department of Examinations, Sri Lanka Department of Examinations, Sri Lanka Department of Examinations, Sri Lanka Department of Examinations, Sri Lanka

අධ්‍යයන පොදු සහතික පත්‍ර (උසස් මට්ටම) විභාග, 2016 අගෝස්තු
கல்விப் பொதுத் தராதரப் பத்திர (உயர் தர)ப் பரீட்சை, 2016 ஆகஸ்ட்
General Certificate of Education (Adv. Level) Examination, August 2016

ජෛවපද්ධති තාක්ෂණවේදය II
 உயிர்முறைமைகள் தொழினுட்பவியல் II
Biosystems Technology II

66 E II

පැය තුනයි
 மூன்று மணித்தியாலம்
Three hours

Index No. :

Instructions :

* This question paper comprises of two parts, Part A and Part B. The time allotted for both parts is three hours.

PART A – Structured Essay : (pages 2 - 6)

Answer all four questions on this paper itself. Write your answers in the space provided for each question. Note that the space provided is sufficient for your answers and that extensive answers are not expected.

PART B – Essay : (pages 7)

* Answer four questions only. Use the papers supplied for this purpose. At the end of the time allotted for this paper, tie the two parts together so that Part A is on top of Part B before handing them over to the Supervisor.

* You are permitted to remove only Part B of the question paper from the Examination Hall.

For Examiner's Use Only

Part	Question Nos.	Marks Awarded
A	1	
	2	
	3	
	4	
B	5	
	6	
	7	
	8	
	9	
	10	
Total		
Percentage		

Final Marks	
In numbers	
In words	

Code Numbers	
Marking Examiner 1	
Marking Examiner 2	
Marks checked by	
Supervised by	

[see page two

Agaram.LK - Keep your dreams alive!

Agaram.LK - Keep your dreams alive!

PART A – Structured Essay
Answer all four questions on this paper itself.

Do not write in this column

1. (A) Biosystems play a big role in maintaining the ecological balance. State **two** other main uses of biosystems.

(i)

(ii)

(B) Solar radiation is considered as one of the important parameters of weather, affecting the biosystems.

(i) State the main reason for the reduction of intensity of solar radiation in Sri Lanka.

.....

(ii) State the main impact of reduced intensity of solar radiation on agricultural biosystems.

.....

(iii) List **two** main impacts of high intensity of solar radiation on the biosystems.

(1)

(2)

(C) Bulk density of a soil is important for the survival of soil biosystems.

(i) State the importance of soil bulk density in agricultural production.

.....

(ii) State **two** main characteristics of a soil that can be manipulated by changing the soil bulk density.

(1)

(2)

(iii) Name a method to measure the soil bulk density.

.....

(iv) Name **two** factors affecting the soil bulk density.

(1) (2)

(D) Asexual propagation techniques are commonly used in commercial agriculture.

(i) State a common natural asexual propagation technique used in floriculture.

.....

(ii) Name a limiting factor in using asexual propagation techniques.

.....

(E) Post-harvest losses in fruits and vegetables are significantly higher compared to losses of other food items.

(i) State **two** reasons for high post-harvest losses in fruits and vegetables.

(1)

(2)

(ii) List **two** methods to minimize post-harvest losses in fruits and vegetables.

(1)

(2)

[see page three

Do not write in this column

0133

(F) Sediments in water create many problems in utilization of water for different purposes.

(i) State a source of sediment that pollutes water.

.....

(ii) Name a chemical which can be used in the process of removing of sediments from water.

.....

Q1

60

2. (A) Food hygiene is one of the most important aspects in the food manufacturing process.

(i) State **two** importance of food hygiene.

(1)

(2)

(B) The barcodes found in the food labels contain various information about the food product.

(i) State **two** important information included in the barcodes found in food labels.

(1)

(2)

(C) Use of Recommended Daily Allowances (RDA) table is an essential requirement in new food product formulation process.

(i) State **three** major information that could be obtained from Recommended Daily Allowances table.

(1)

(2)

(3)

(D) Oven drying method can be used to determine the moisture content of a food product.

(i) State **three** important steps to be followed to obtain accurate results through oven drying method.

(1)

(2)

(3)

(E) Following is a figure showing dimensions of a lawn adjacent to a house.

(i) Calculate the area of the lawn.

.....

.....

.....

.....

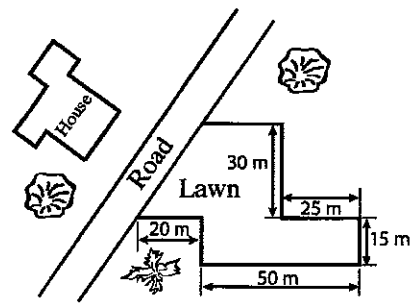

(ii) Mark the most suitable place on the figure to locate the plane table for making a map of this lawn.

.....

(iii) If chain surveying is used for mapping the above lawn, state the minimum number of off sets to be taken for completing the map of the lawn.

.....

[see page four

Do not write in this column

(F) Use the following diagram to answer questions (i) to (iii).

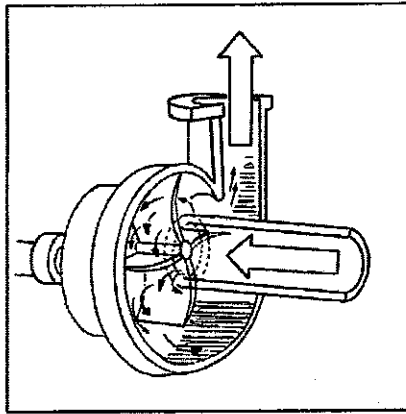

(i) State the agricultural use of this implement.

.....

(ii) What is the principle used in this implement for the use you mentioned in (i) above?

.....

(iii) State a reason why this instrument is widely used in agriculture.

.....

(G) Following diagram shows a draft sketch provided by a land owner highlighting his landscape requirements.

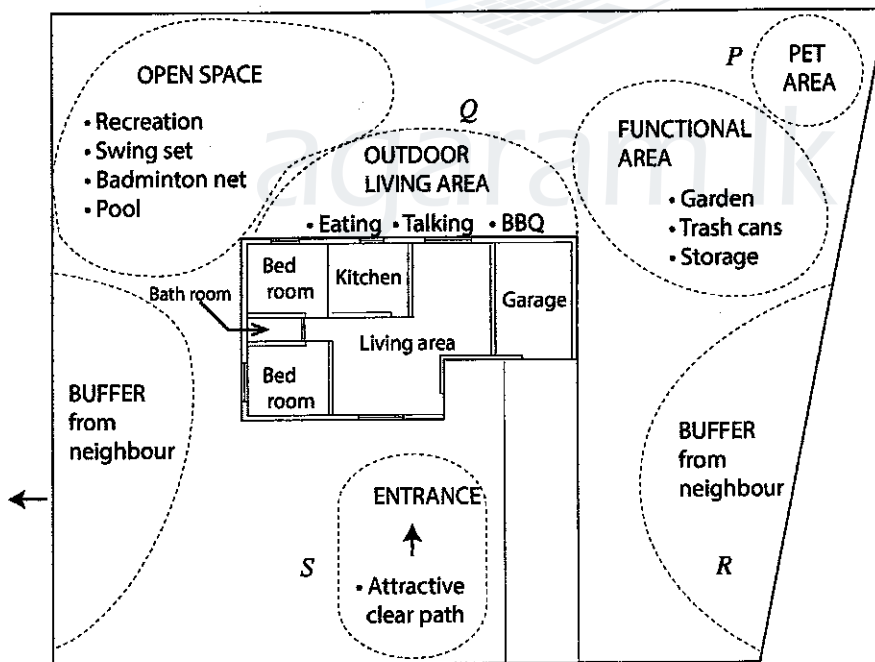

(i) State a suitable plant type for each of the locations P, Q, R and S.

- (1) P -
- (2) Q -
- (3) R -
- (4) S -

Q2

60

Do not write in this column

3. (A) The water delivery subsystem is one of the important subsystems of an irrigation scheme.

(i) Mention **two** measures that can improve the efficiency of a conventional water delivery subsystem.

(1)

(2)

(ii) Mention a measure that can be employed to increase the efficiency of the water use subsystem of a surface irrigation system.

.....

(iii) If a sub-surface irrigation system is used to irrigate a crop, state the most important soil characteristic that need to be considered prior to installation of the system.

.....

(iv) If excess water is accumulating in the water use subsystem, state a measure that should be implemented to correct this situation.

.....

(B) Pest management is important in agriculture as pest damages are very high in tropical environment.

(i) List, in order, the **four** pest management strategies described in Integrated Pest Management.

(1)

(2)

(3)

(4)

(ii) When deciding on management options for a pest problem, what are the **two** most important factors to be considered?

(1)

(2)

(C) Artificial insemination is popular among Sri Lankan dairy farmers, as it is one of the cost effective ways to increase the milk production.

(i) Name **two** visual parameters considered in semen evaluation in the semen processing for artificial insemination.

(1)

(2)

(D) Improper management of livestock creates soil, air and water pollution.

(i) Name **two** air pollutants generated in livestock industry and state a measure to minimize each of the pollutants.

Pollutant

Measure to minimize

(1)

(2)

(E) State **two** differences between AA and B type eggs.

(1)

(2)

(F) Name a destination famous for adventurous eco-tourism in Sri Lanka.

.....

Q3

60

[see page six

Do not write in this column

4. (A) The teacher observed an off colour and separation of liquid and solid in a mango cordial prepared by a group of students.

(i) State one major reason for each of these defects.

Defect	Reason
(1) Off colour
(2) Separation of liquid and solid

(B) Name the **three** major components of a portable milking machine.

- (1)
- (2)
- (3)

(C) State **two** main objectives of primary land preparation.

- (1)
- (2)

(D) Name **two** farm structures used in commercial crop production.

- (1)
- (2)

(E) Feed plays an important role in survival and growth of newly hatched fish larvae.

(i) Name **two** feeds commonly used for ornamental fish larvae.

- (1)
- (2)

(F) Write **two** differences between an open loop control and a closed loop control system.

- (1)
- (2)

(G) List **two** reasons why forests are considered as biodiversity reserves.

- (1)
- (2)

(H) Name **two** reasons why Gliricidia is considered as one of the best biomass energy sources.

- (1)
- (2)

(I) Name a legislative enactment which deals with the occupational health and safety issues in Sri Lanka.

.....

(J) Entrepreneurs use different strategies to improve their enterprises.

(i) List **two** such strategies commonly used by entrepreneurs.

- (1)
- (2)

**

Q4

60

[see page seven

AL/2016/66-E-II

- 7 -

සියලු ම හිමිකම් ඇවිරිණි / முழுப் பதிப்புரிமையுடையது / All Rights Reserved]

ශ්‍රී ලංකා විභාග දෙපාර්තමේන්තුව ශ්‍රී ලංකා විභාග දෙපාර්තමේන්තුව ශ්‍රී ලංකා විභාග දෙපාර්තමේන්තුව ශ්‍රී ලංකා විභාග දෙපාර්තමේන්තුව ශ්‍රී ලංකා විභාග දෙපාර්තමේන්තුව
 இலங்கைப் பரீட்சைத் திணைக்களம் இலங்கைப் பரීட்சைத் திணைக்களம் இலங்கைப் பரීட்சைத் திணைக்களம் இலங்கைப் பரීட்சைத் திணைக்களம் இலங்கைப் பரීட்சைத் திணைக்களம்
 Department of Examinations, Sri Lanka Department of Examinations, Sri Lanka Department of Examinations, Sri Lanka Department of Examinations, Sri Lanka Department of Examinations, Sri Lanka
 ශ්‍රී ලංකා විභාග දෙපාර්තමේන්තුව ශ්‍රී ලංකා විභාග දෙපාර්තමේන්තුව ශ්‍රී ලංකා විභාග දෙපාර්තමේන්තුව ශ්‍රී ලංකා විභාග දෙපාර්තමේන්තුව ශ්‍රී ලංකා විභාග දෙපාර්තමේන්තුව
 இலங்கைப் பரීட்சைத் திணைக்களம் இலங்கைப் பரීட்சைத் திணைக்களம் இலங்கைப் பரීட்சைத் திணைக்களம் இலங்கைப் பரීட்சைத் திணைக்களம் இலங்கைப் பரීட்சைத் திணைக்களம்
 Department of Examinations, Sri Lanka Department of Examinations, Sri Lanka Department of Examinations, Sri Lanka Department of Examinations, Sri Lanka Department of Examinations, Sri Lanka

අධ්‍යයන පොදු සහතික පත්‍ර (උසස් පෙළ) විභාග, 2016 අගෝස්තු
 கல்விப் பொதுத் தராதரப் பத்திர (உயர் தர)ப் பரீட்சை, 2016 ஆகஸ்ட்
 General Certificate of Education (Adv. Level) Examination, August 2016

ජෛවපද්ධති තාක්ෂණවේදය II
 உயிர்முறைமைகள் தொழினுட்பவியல் II
 Biosystems Technology II

66 E II

Part B - Essay

Instructions:

- * Answer four questions only.
- * Give clearly labelled diagrams where necessary.

5. (a) Describe the soilless agricultural techniques that can be used in urban home gardens.
 (b) Describe how you would setup a dumpy level in a field for elevation measurements.
 (c) Describe the different methods of food fermentation and their advantages.
6. (a) Describe the major steps involved in the new food product development process.
 (b) Explain how to make an automated ventilation system for a polytunnel to reduce the inside temperature.
 (c) Describe the mechanical methods of weed control in agricultural fields.
7. (a) Describe the problems faced in obtaining plant exudates.
 (b) Explain the operation of a centrifugal pump.
 (c) Describe the factors to be considered in establishing a micro-irrigation system.
8. (a) Explain the basic requirements for maintaining of a commercial foliage plant cultivation for export market.
 (b) Describe different methods of power transmission used in agricultural machineries.
 (c) Describe the effect of irrigation and fertilizer application on the post-harvest losses of crops.
9. (a) If you are planning to start a bakery, describe the supporting services needed to run the bakery profitably.
 (b) Explain the potential for the development of the fishery industry in Sri Lanka.
 (c) Describe the methods to enhance the groundwater recharge.
10. (a) Describe the effect of weather on the aquaculture industry.
 (b) Explain the positive impacts of using novel technologies in the livestock management.
 (c) Describe the strategies you would suggest to get rid of the present energy crisis in Sri Lanka.

* * *



agaram.lk