



Royal College - Colombo 07

රාජකීය විද්‍යාලය - කොළඹ 07

Grade 11 – Second Term Test – January 2022

දෙවන වාර පරීක්ෂණය - 2022 ජනවාරි - 11 ශ්‍රේණිය

කාලය : පැය 1
Time : 1 hour

Science – I

34

E

I

විද්‍යාව – I

Name :- Grade: -..... Index number:-.....

❖ Answer all the question

❖ Select the most appropriate answer and mark a cross (x) on the number cores pounding to your choice in the answer sheet.

1. Which of the following is an angiosperm : plant ?

- (1) Pogonatum (2) Cycas (3) Salvinia (4) Almonds

2. What is the unit of momentum?

- (1) kgms^{-2} (2) kgms^{-1} (3) $\text{kgm}^2\text{s}^{-2}$ (4) $\text{kgm}^{-1}\text{s}^{-1}$

3. Select the heterogeneous mixture?

- (1) Sugar + Water (2) Salt + Water
(3) Camphor + Water (4) Ethanol + Water

4. Which of the following does not contain in glomerular filtrate ?

- (1) Platelets (2) Glucose (3) Amino acids (4) Vitamin C

5. The standard form of element sodium is given below. Select the correct statement about sodium? ${}_{11}^{23}\text{Na}$

- (1) The mass number of sodium atom is 23g
(2) One mole of sodium contain 23 atoms.
(3) The mass of 6.022×10^{23} of sodium atoms are 23g.
(4) The mass of twenty three sodium atoms are 6.022×10^{23} g.

6. By adding iodized salt to the diet as needed,

- (1) Heart diseases can be prevented
(2) Skin diseases can be prevented
(3) Goiter can be prevented
(4) Anemia can be prevented

7. A ball is projected vertically upwards at an initial velocity of 20ms^{-1} . What is the maximum height reached by the ball and the time taken by the ball to reach its maximum height?
- (1) 20m and 4s (2) 40m and 4S
(3) 20m and 2S (4) 20m and 4s
8. The element M reacts with chlorine gas and forms an ionic compound MC1_2 . Which of the following might be the electronic configuration of M?
- (1) 2, 6 (2) 2, 8 (3) 2, 8, 2 (4) 2, 8, 8
9. What are the phenomena agreed to Newton's third law?
- (1) Water falling down a waterfall.
(2) Changing the direction of motion of a moving object.
(3) A falling ball hits the ground and bounces off.
(4) Obtaining the maximum velocity when a stone thrown up reaches the ground.
10. What is the displacement – time graph that represents the motion of a small ball that is stationary on a smooth horizontal table when a constant horizontal force is applied to it?

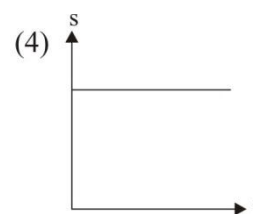
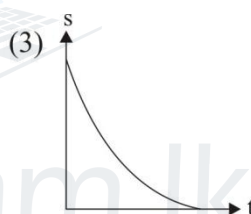
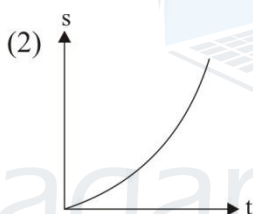
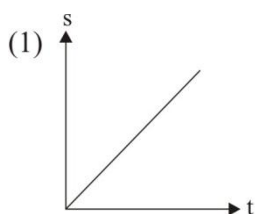

11. In which instance does meiosis take place?
- (1) Growth of all the somatic cells.
(2) When producing eggs and sperms.
(3) The zygote during embryonic development.
(4) When the morula becomes foetus.
12. What contains the same number of atoms as atoms in 12g of carbon?
- (1) of Nitrogen 7g (2) of Hydrogen 2g
(3) of Magnesium 24g (4) of Nitrogen 28g
13. Where is urea $[\text{CO}(\text{NH}_2)_2]$ produced in the human body?
- (1) In the stomach (2) In the kidneys
(3) In the liver (4) In the lungs

18. The incorrect statement regarding COVID – 19 virus is,
- (1) No any metabolic activities take place
 - (2) Cannot be observed ever with a high powered light microscope.
 - (3) Carries a nucleus with RNA
 - (4) Represents both living and not living features
19. Select the answer that gives the correct scientific name of shoe flower plant.
- (1) Hibiscus Rosasinensis
 - (2) *Hibiscus rosasinensis*
 - (3) HIBISCUS ROSASINENSIS
 - (4) Hibiscus rosasinensis
20. The sea rooster is,
- (1) A bird species
 - (2) Fish species
 - (3) Mammal
 - (4) Amphibian
21. The function of testosterone hormone is,
- (1) Controlling the growth of the body.
 - (2) Controlling the amount of sugar in blood.
 - (3) Controls the secondary sexual characteristics of female.
 - (4) Controls the secondary sexual characteristics of males.
22. A plant with an underground stem is,
- (1) Carrot
 - (2) Sweet potato
 - (3) Potato
 - (4) Manioc
23. A feature that cannot be seen in a zoophilus flower is,
- (1) Having nectaries
 - (2) Having colourful petals
 - (3) Stigma is branched
 - (4) Pollen being sticky
24. A factor that does not affect the pressure of a point in a liquid is,
- (1) Volume of the liquid
 - (2) Density of the liquid
 - (3) Gravitational acceleratory
 - (4) The depth of the liquid column from the surface

25. Choose the answer that which shows that reducing the pressure on an object is beneficial?
- (1) Easy to cut something using a sharp knife
 - (2) Easy to inject by using a sharp needle
 - (3) Difficulty sewing with a blunt needle
 - (4) When a plank is placed under the jack, it is difficult to sink
26. A stone weighing 3kg falls from a height of 10m. what is the gravitational potential energy of the rock at the initial position ($g = 10\text{ms}^{-2}$)
- (1) 3×10 J
 - (2) $3 \times 10 \times 10$ J
 - (3) $\frac{3 \times 10}{10}$ J
 - (4) $\frac{1}{2} \times 3 \times 10 \times 10$ J
27. The following statements are about electromagnetic waves,
- A. Waves propagate perpendicular to both electric and magnetic fields.
 - B. A medium is not required for the wave to propagate.
 - C. They are not affected by external electric or magnetic fields.
- Which of the above are true?
- (1) A only B only
 - (2) B and C only
 - (3) A and C only
 - (4) A, B, C all
28. Prawn's exoskeleton is made of
- (1) Curtin
 - (2) Chitin
 - (3) Calcium
 - (4) Keratin
29. Self – sterility is a plant adaptation to prevent self-pollination. What is an example of that?
- (1) Tridax
 - (2) Nutmeg
 - (3) Passion fruit
 - (4) Orange
30. Some chemical reactions are exothermic. In such a reaction.
- A. The temperature of external environment rises.
 - B. Energy contained in reactants is less than the energy contained in products.
 - C. An increase in the temperature of the external environment causes a decrease in the rate of the reaction.
- Which of the above are incorrect?
- (1) A only B only
 - (2) B and C only
 - (3) A and C only
 - (4) A, B, C all

31. What is the tissue that transports water throughout the plant body?

- (1) Xylem tissue (2) Phloem tissue
(3) Sclerenchyma tissue (4) Parenchyma tissue

32. What is not an importance of the process of photosynthesis?

- (1) Contributes to maintain the carbon cycle.
(2) Conversion of light energy into chemical energy.
(3) Maintain the balance of the amount of oxygen and carbon dioxide in the atmosphere.
(4) Maintain the environmental temperature constant by absorbing solar heat.

33. The compound X is recrystallized into a pure substance. What could be its solubility (S) and temperature graph?

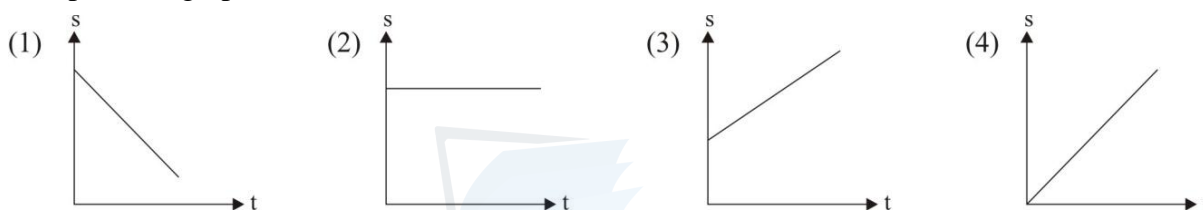

34. Always the image of an object placed in front of a concave lens is,

- (1) Magnified (2) Virtual
(3) Diminished (4) Upright

35.

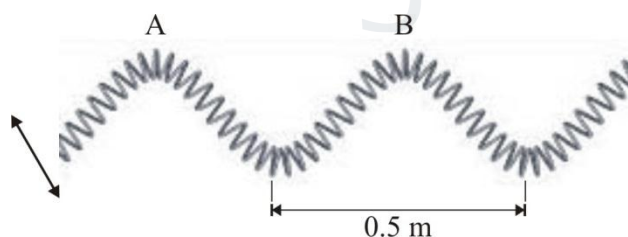

The figure shows how to create a wave using a slinky. If the frequency of the wave formed there, is 317Hz, find the time it takes to travel 6m?

- (1) 15 (2) 25 (3) 35 (4) 45

36. A disease caused by inhaling dirty air is,

- (1) Bronchitis (2) Nephritis
(3) Gastritis (4) Thrombosis

37. What colour could be the litmus paper dipped in lime juice.

- (1) Red (2) Blue (3) Yellow (4) Orange

38. What are formed by the reaction of an acid and base?

- (1) Salt and water
 (2) Salt and H^+ ions
 (3) Oxygen and water
 (4) Base and salt

39. Which of the following is an energy level diagram for an endothermic reaction.

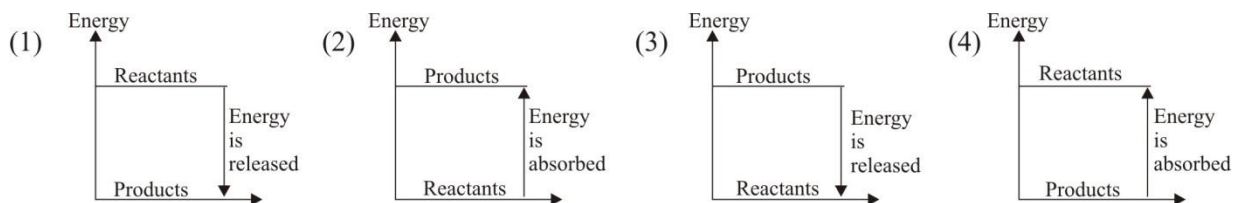

40. At present the number of deaths due to non-communicable disease is increasing rapidly. Some suggestions for preventing non-communicable disease are mentioned below.

- A. Encouraging people to consume natural foods.
 B. Absolute ban on artificial food.
 C. Directing people to exercise and mental well-being.

Which of these are true?

- (1) A only B only
 (2) B and C only
 (3) A and C only
 (4) A, B, C all

agaram.lk



Royal College - Colombo 07

රාජකීය විද්‍යාලය - කොළඹ 07

Grade 11 – Second Term Test – January 2022

දෙවන වාර පරීක්ෂණය - 2022 ජනවාරි - 11 ශ්‍රේණිය

කාලය : පැය 3
Time : 3 hours

Science – I

34

E

II

විද්‍යාව – I

Name :- Grade: -..... Index number:-.....

STRUCTURED ESSAY - PART A

- ❖ Answer all the questions in part A on the space provided.
- ❖ Answer only 3 questions in part B

01. A. Fertilizers are added to soil when the minerals in the soil are not enough for plant growth. Fertilizers can be divided in to two groups as chemical fertilizers and organic fertilizers.

(I) Which one is the environmental friendly fertilizer out of the above two types. (01 M)

.....

(II) Write one advantage and disadvantage of using organic fertilizers. (02 M)

Advantage -

Disadvantage -

(III) Write two mineral salts that are added to soil when applying chemical fertilizers. (02 M)

.....
.....

(IV) Due to the deficiency of which element, the red and purple patches appear on leaves of plants? (01 M)

.....

(V) In which bio molecule does the above mentioned element in (IV) contains? (01 M)

.....

B. Many diseases are caused by entering artificially synthesized agro chemical in to human bodied.

(I) What is the main nitrogenous excretory organ in human body? (01 M)

.....

(II) Write one disease occur in the above mentioned organ. (01 M)

.....

(III) Write the name of the salt which is deposited as bladder stones. (01 M)

.....

(IV) Write one food habit that causes for bladder stones. (01 M)

.....

C. Cancers occur due to entering of artificial chemical substances in to human bodies. Cancer patients are frequently reporting through out of the country at present.

(I) Name the cell division method of cancer cells. (01 M)

.....

(II) What is the other cell division method can be seen in body cells? (01 M)

.....

(III) Name one instance in which the cell division method mentioned in (II) above can be seen in organisms. (01 M)

.....

(IV) One of the above cell division methods is important as asexual reproduction method. What is that cell division method? (01 M)

.....

.....

(15 Marks)



02. Plants are considered as autotrophic organisms. Their reproductive structure is the flower.

A. (I) Plants can be divided in to two groups based on the ability of bearing flowers. What are they? (02 M)

.....

.....

(II) What is the male reproductive part of a flower? (01 M)

.....

(III) Name the two parts of a stamen (02 M)

.....

.....

B.



A leaf of a dicotyledonous plant is given in the figure.

(I) State a structural feature that can be used to identify this as a dicot leaf. (01 M)

.....

(II) Which type of root system can be seen in the above dicot plant. (01 M)

.....

(III) Write one feature of dicot stem. (01 M)

.....

(IV) Some plant stems are situated under the soil. These stems are known as underground stems. State a main function of it. (01 M)

.....

(V) One such underground stem is used as a traditional food colouring and disinfectant. Name that underground stem. (01 M)

.....

C. Photosynthesis is a main function of plant leaf.

(I) Name another function performed by plant leaf. (01 M)

.....

(II) What is the main product of photosynthesis. (01 M)

.....

(III) Write the word equation for photosynthesis. (02 M)

.....

(IV) As which compound the translocation of food occurs in plant stems. (01 M)

.....

(15 Marks)

03. Periodic table can be considered as a successful step of classification of elements.

A. (I) Name the scientist who introduced the modern periodic table first. (01 M)

.....

(II) The periodic table is based on two factors. Name them (02 M)

1)

2)

(III) A part of the periodic table is given below.

H						He
Li				O	F	
Na		Al			Cl	
K						

Write the answer for given questions using above periodic table.

- a) Which element has the highest first ionization energy? (01 M)
.....
- b) Write the element having highest electronegativity. (01 M)
.....
- c) Write the electronic configuration of element sodium. (01 M)
.....
- d) Write the formula of the compound formed by aluminum and chlorine. (01 M)
.....

B. Changes that occur in substances are two type, as chemical changes and physical changes.

- (I) Name the compound which is used in the lab for the preparation of oxygen gas frequently? (01 M)
.....
- (II) To which type of reaction does the above mentioned reaction belongs. (01 M)
.....
- (III) Which chemical property of oxygen is used to test oxygen gas. (01 M)
.....
- (IV) Write the collection method of oxygen gas in above preparation. (01 M)
.....

C. Reactions occur in different speeds. Some reactions occur faster while some reactions occur slowly.

- (I) Which name is used for the amount of changes that occurs is a unit time during a chemical reaction (01 M)
- (II) Write two factors affect on speed of a reaction.
.....
.....

(III) Porous iron is used as a catalyst in manufacturing ammonia in Haber process. Write the balanced equation for the above reaction of ammonia production. (01 M)

.....

(15 Marks)

04. The below diagram illustrate an activity done by a group of students to find the amount of heat required to heat water at 30 °C until boils.

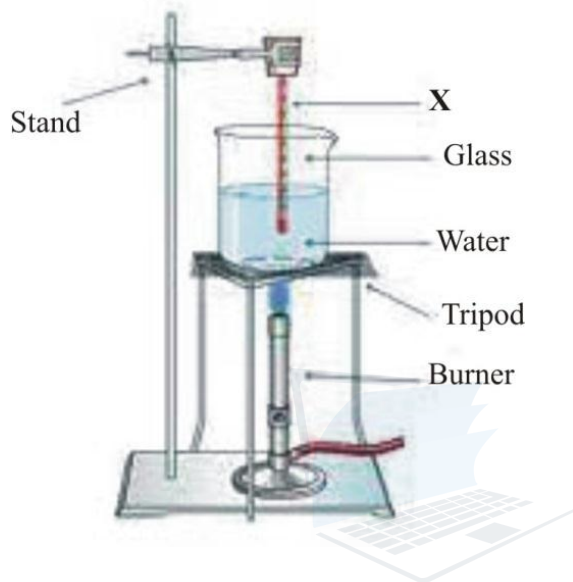

A. (I) Name the instrument X (02 M)

X

(II) What is the maximum value recorded in X during the given activity? (01 M)

.....

(III) What is the temperature change occurs hear. (01 M)

.....

(IV) Give the reason for heating up water slowly than other liquids. (01 M)

.....

B. A stone is thrown vertically upwards with a velocity of 30ms⁻¹.

(Gravitational acceleration = 10ms⁻²)

(I) What is the velocity of the stone at the maximum height. (01 M)

.....

(II) How long will it takes to reach the maximum height? (01 M)

.....

(III) Calculate the maximum height reached by this stone. (01 M)

.....

(IV) If the stone falls down back, calculate the velocity of stone when it reaches the initial position? (01 M)

.....

C. The following diagram illustrate how two optical instruments have been used for changing a beam of light.

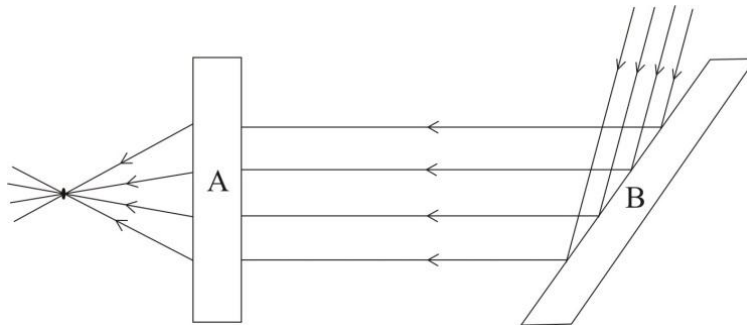

(I) Name A and B optical instruments? (02 M)

A.

B.

(II) Which instrument out of A and B can be used to magnify small letters. (01 M)

.....

(III) Write two features of the image formed by the optical instrument B. (02 M)

.....
.....

(IV) Which phenomena related to light occurs in A and B instruments. (02 M)

.....
.....

(15 Marks)

STRUCTURED ESSAY PART B

01. A. Autotrophic macro organisms are known as plants.
- (I) Name the kingdom to which plants belong. (01 M)
- (II) Write two structural features that can be seen only in this kingdom. (02 M)
- (III) There are 4 main parts of a flower name them (04 M)
- (IV) An important part of a flower is given in the figure.

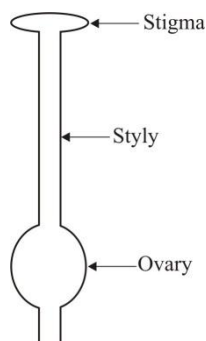

- a) Write the name of the part represented this figure. (01 M)
- b) What is the name of male gametes produced in stamens? (01 M)
- c) What happens to the stamens after pollination? (01 M)

- B. A part of human digestive system is given below. (02 M)

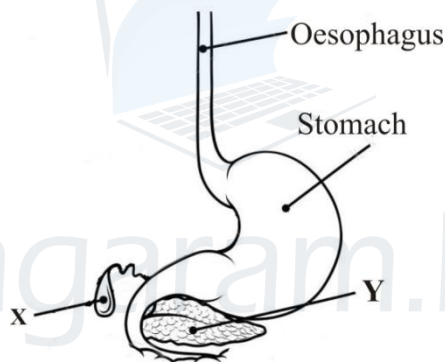

- (I) Name X and Y structures.
- (II) One of the organ given above digest food mechanically. Name that organ. (01 M)
- (III) What name is used for the food mixture formed after this mechanical digestion? (01 M)
- (IV) Hydrochloric acid is contained in gastric juice. Write the function of it. (01 M)
- (V) What is emulsification of lipids. (01 M)

- C. Most of the parts in the digestive system consists of smooth muscle tissue.

- (I) Name the other two muscle tissue type present in human body. (02 M)
- (II) Some muscle tissues are striated. What is the meaning of this? (01 M)
- (III) Smooth muscles contract without the control of central nervous system. Give one word for this (01 M)

(20 Marks)

02. A. Substances with a mass and occupy space are called matter. The basic structural and functional unit of matter is the cell.
- (I) Write the three sub atomic particles in the atom. (03 M)
- (II) Write their charges separately (03 M)
- (IV) Rutherford found important factors about the nucleus using gold leaf electroscope test.
- a) Write the sub atomic particle / particles contained in the nucleus. (01 M)
- b) Which sub atomic particle revolve around the nucleus. (01 M)
- B. Ions of sodium and chlorine are combined chemical to produce sodium chloride.
- (I) Write the electronic configuration of sodium atom. (01 M)
- (II) Write the symbol of sodium ion (01 M)
- (III) There are two types of chemical bonds what are they. (02 M)
- (IV) Name the bond type present in water molecule (01 M)
- (V) There are two lone pairs in the water molecule. Write what are called lone pairs. (01 M)
- C. Unexpected blasts and fires occur due to leakage of L.P. gas.
- (I) Explain what happens during burning of L.P. gas (01 M)
- (II) Combustion is chemical reaction. Name two observations that can be obtained during a chemical reaction. (02 M)
- (III) During the combustion of L.P. gas. Carbon dioxide and water vapour are produced as products.
- a) Write one physical property and chemical property of carbon dioxide gas. (02 M)
- b) Write one use of carbon dioxide gas. (01 M)
- (20 Marks)

03. A. The diagram given below illustrates the set of apparatus used for verification of ohms law.

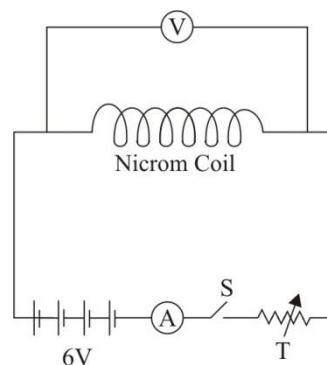

- (I) Name the instruments S and T (02 M)
- (II) Write the type of readings obtained from the equipments shown as $\text{---}\text{A}\text{---}$ and $\text{---}\text{V}\text{---}$ separately. (02 M)
- (III) Write one factor that should be considered when taking the above readings. (01 M)
- B. Hydrometer is used to measure density of a liquid.
- (I) Hydrometer has manufactured based on a particular scientific law. Name that law. (01 M)
- (II) Write that law (02 M)
- (III) Hydrostatic pressure increases when the depth of a liquid increases.
- a) Define pressure. (02 M)
- b) List down three factors effect on hydrostatic pressure. (03 M)
- C. Changing the position and shape of an object applying a force is called work.
- (I) What is the relationship between work done force applied and distance moved by an object. (02 M)
- (II) Write two units which are used to measure “work done” (02M)
- (III) What is “energy” ? (01 M)
- (IV) Calculate the kinetic energy of a dog which has a mass of 10kg when runs with a velocity of 8ms^{-1} . (02 M)
- (20 Marks)
04. A. Prawn and sea horse are two aquatic organisms.
- (I) Name the Domain to which sea horse and prawn belongs. (01 M)
- (II) What are the kingdoms of the above mentioned domain. (02M)
- (III) Prawn and sea house of two animal groups. Which feature has used for above grouping. (01 M)

- (IV) Write one difference can be seen in the skeletal system of sea horse and prawn. (01 M)
- (V) In which organism's body given above can identify tagma? (01 M)
- (VI) Animals in which group that the above mentioned animals belong, possess streamlined body shape? (01 M)

B. A figure of optic fibre is given below.

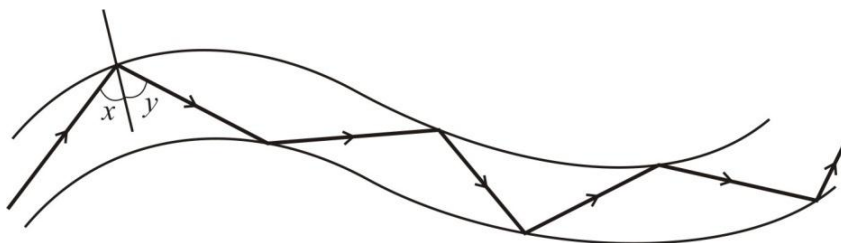

- (I) Name the phenomena that occurs in the above optic fibre. (01M)
- (II) What can you say about the values of x and y angles. (01M)
- (III) In which medical instrument, the above mentioned optical fibre technology have been used? (01 M)
- (IV) Mention another instance where the optical fibres are used in day to day purposes. (01 M)
- (V) State whether the magnitude of angle X is equal, greater than or less than the critical angle which formed in glass-air interface. (01 M)

C. Different types of mirrors are used in our day to day purposes.

- (I) Write two instances where plane mirrors are used. (02M)
- (II) In which type of mirrors always form a virtual images. (02M)
- (III) Which type of mirrors are used by dentists to observe teeth? (01M)

D. Following description was provided by sales assistant to a person who needed to buy an iron.

Iron A – Power 1200W. Spend 6s to heated up.

Iron B – Power 760W. Spend 10s to heated up.

- (I) Which iron out of A and B is suitable to reduce electricity bill of the house. (01M)
- (II) Explain your answer with a calculation. (02M)

(20 Marks)

05. A. Two reactions of X metal are given below.

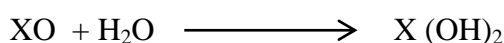
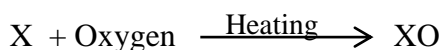

X(OH)₂ is a colourless aqueous solution.

- (I) Write the valencies of the metal X and oxygen separately. (01 M)
- (II) Which metal out of Sodium, Magnesium, Aluminum can be considered as X ? (01 M)
- (III) State whether X(OH)₂ solution is acidic or basic. (01 M)
- (IV) Write the colour changes of above solution with following indicators separately.
- a). Phenolphthalein
- b). pH papers (02 M)
- (V) 50cm³ of X(OH)₂ solution and HCl were mixed in a heat insulating vessel.
- a). Write the balanced chemical equation for the reaction between X(OH)₂ and HCl. (02 M)
- b). If temperature incensement of 5⁰C was observed during the reaction calculate the heat change of above reaction. (02 M)
(Specific heat capacity of water 4200Jkg⁻¹ K⁻¹, density of water gcm⁻³)
- B. The air layer around the earth is called atmosphere.
- (I) What is meant by atmospheric pressure? (01 M)
- (II) The value of atmosphere pressure at sea level is 76 cmHg.
- a). Atmosphere pressure at sea level is 76 cmHg. What is meant by this? (01 M)
- b). Which laboratory equipment is used to obtain the above reading. (01 M)
- c). What happens to the atmospheric pressure when altitude increases?(01 M)
- d). Explain the reason for your answer (02 M)
- e). Calculate the atmospheric pressure at sea level in Pascal (03 M)
(Density of mercury = 13600kgm⁻³ and gravitational acceleration is 10ms⁻²)
- f). Mention the reason for using mercury as a liquid in barometers, than water or any other liquid. (02 M)
- (20 Marks)